



TERRAIN

EX4

USER MANUAL



LOOKING BEYOND
100% ELECTRIC



CORVUS INNOVA, Limited Company.

CORVUS OFF-ROAD VEHICLES® We reserve all commercial rights and/or the right to exploit the brand. As CORVUS is constantly seeking new ways to improve the specifications, design and quality of its utility vehicles, ongoing modifications may take place. That is why the information in this catalogue may have changed since the time of printing. CORVUS reserves the right to modify models, colours, and/or technical specifications without notice and without incurring any obligation.

Drivers of CORVUS vehicles must comply with all requirements demanded by current legislation in relation to driving licenses and security measures required for the proper use of such vehicles. NEVER perform acrobatics and avoid excessive speeds and abrupt turns. Never drive under the influence of alcohol or drugs.

USER MANUAL

CRVS-MU-23-ENG-EX4-123-1.0

CONTENT

General information	4	9. Especificaciones	26	Maintenance	48
1. Introduction	5	10. Multifunction panel	27	18. Safety and maintenance stand-ards	49
2. Legal notices	5	Warning indicators	29	19. Service chart	50
3. Cautions and warnings	5	On-screen notifications	30	20. Rasing the vehicle	51
4. Preliminary warnings	6	Functionalities	31	21. Underbody protector	52
5. Vehicle identification	7	Settings screen	34	22. Wheels	53
6. Exterior components	8	Maintenance screen	35	23. Transmission oil	53
7. Driving seat	9	Charge screen	35	24. Rear differential oil	54
8. Location of components	10	Usage information	36	25. Front differential oil	55
Ignition key	11	11. Daily inspection before driving	37	26. 4WD locking system oil	56
Storage compartment key	11	12. Starting the vehicle	38	27. Grease nipples	57
Light switch	12	13. Use of the 2WD/4WD driveline	43	28. Luggage compartment hood	58
Instrument panel	12	14. Use of the rear differential lock and unlock	44	29. Lighting	58
Gearshift level	13	15. Driving tips	44	Pilot lights	60
2WD/4WD drivenline switch	13	General information	45	Adjusting the height	60
Rear differential loock switch	14	Turning precautions	45	30. Front lamps	61
Gear Selector	14	Driving on slopes or hills	45	31. Lamps	62
Power range selector	15	Paved surfaces	45	Number plate holder bulb	63
Parking brake	15	Driving through water	45	32. Tires	63
Audible warning device	16	High-speed driving	46	33. Bolts, nuts and fastenings	64
Rear-view mirrors	16	Driving in or near wooder or bushy areas	46	34. Adjust handbrake	64
Safety belts	17	Driving on ice or snow	46	34. Brake wear	64
Steering wheel adjustment	17	Driving on dunes or sandy terrain	46	36. Brake fluid	65
Luggage compartment hood	18	Driving in low visibility conditions	46	37. Auxiliar battery	65
Cargo box	19	Reverse gear	46	38. Battery	66
Tilting the cargo box	20	Unfamiliar Terrain	47	39. Engine	67
Unloading the box	21	Driving with a load	47	40. Fuses	69
Charging the battery	22	Actions in case of veh. damage or rollover...	47	41. Windshield wiper	70
Trailer	24	16. Cleaning the vehicle	47	Windshield wiper blade	71
Inside storage compartments	25	17. Vehicle storage	48	Windshield cleaner fluid	71



GENERAL INFORMATION

I. INTRODUCTION

We are delighted to be able to congratulate you on the purchase of your **CORVUS** vehicle and we would like to thank you for the confidence you have placed in us.

You are now the owner of a modern multi-purpose work vehicle that you will enjoy a lot if you care for it and maintain it adequately. Before you start it up for the first time, please read the instructions of use carefully to become familiar with the handling and the characteristics of your vehicle. Only in this way will you be able to understand how to best adapt your vehicle to your requirements and how to avoid accidents. For your safety we recommend that you use only spare parts and accessories authorized by **CORVUS**.

If you use any other products, **CORVUS** declines all liability for any damages that may arise from so doing. We recommend you follow the instructions on the driving-in period and maintenance intervals in order to prolong the life of your vehicle. For maintenance work, you should always consult an official **CORVUS** distributor or dealer.

Driving in the countryside is fascinating and we hope you will enjoy it to the full. Although **CORVUS** vehicles are environmentally friendly, environmental problems and conflict with other people may ensue in the countryside. Handling the vehicle in a responsible way ensures that these problems and conflicts do not arise. Be sure to use the vehicle within the bounds of the law, show that you are environmentally aware and respect the rights of others.

#100% WORK
#100 % ELECTRIC

2. LEGAL NOTICES

In the interest of technical development, **CORVUS INNOVA S.L.** reserves the right to modify the construction, equipment and accessories of its vehicles without notice. Size, weight and power data should be understood with the respective tolerances. Depending on the volume of your **CORVUS'** equipment and accessories, and on the versions that are approved in compliance with the different laws of each State, there may be variations with regard to descriptions and illustrations. The photographs in this manual may not therefore correspond to the model you have purchased. For this reason, no liability can be derived from any error, printing error or omission.

In the event of any discrepancy or question about the content of this manual, we recommend that you contact our After-sales Service.

3. CAUTIONS AND WARNINGS

YOU SHOULD READ THIS MANUAL CAREFULLY AND COMPLETELY BEFORE YOU ENJOY USING IT FOR THE FIRST TIME. IT CONTAINS INFORMATION AND SUGGESTIONS THAT WILL FACILITATE THE USE AND HANDLING OF THE VEHICLE. PAY PARTICULAR ATTENTION TO THE FOLLOWING WARNINGS THAT CAN BE FOUND IN THE MANUAL:



A warning concerning a hazard that can cause damage to the vehicle.



A warning concerning a hazard that can lead to personal and/or serious injury and even death.

4. PRELIMINARY WARNINGS

ADVERTENCIA

Take the appropriate precautions while driving, especially during turning maneuvers; driving on slopes or in areas with obstacles may cause a collision or rollover of the vehicle.

Only persons with a driving license should operate this vehicle. It is advisable that the driver and their passenger use helmets and protective glasses while using the vehicle. Do not perform jumps or stunts with the vehicle, be attentive to changes in the terrain you are driving over.

Check the obstacles you wish to overcome, do not attempt to overcome large obstacles, such as fallen trees, rocks, slopes, muddy areas, etc.

In slippery areas, be careful and drive at low speed, be attentive to possible loss of grip, do not tackle steep slopes.

It is necessary to charge the vehicle periodically, at least once a month, especially if the vehicle is new.

Always complete charging cycles to 100% and let the charger stop.

Corvus recommends that the driver of the EX4 has received off-road driving information prior to the first use of this vehicle.

ELECTROMAGNETIC INTERFERENCE

This vehicle emits a reduced level of electromagnetic energy. People with implantable medical devices, whether active or inactive (such as heart monitoring and control devices), should review the limitations of their device and the electromagnetic standards and regulations applicable to this vehicle.

DANGER

You should not use the vehicle in a way that is not in line with the criteria and instructions contained in this manual or in a way that may cause damage to persons or things.

These are some examples of unsafe use and misuse:

- Driving with more than two people in the vehicle.
- Not keeping the entire body inside the cabin.
- Transporting people in the cargo box.
- Transporting minors who require child safety seats or booster seats. The vehicle is not designed to secure car safety seats for minors.
- Not complying with the instructions for use and maintenance set forth in this manual.
- Exceeding the cargo and towing limits.
- Driving on unstable or not consolidated ground.
- Circular por terrenos con inclinación superior al 15%.
- Driving in flooded areas (Do not drive through water if it rises above the centre of your wheel rims).
- Driving in forestry operation sites where the risk of falling objects may be present. This vehicle does not have a Falling Object Protective Structure (FOPS).
- Using accessories, parts or equipment that are not authorised by **CORVUS**.
- Failure to charge the vehicle can result in unrecoverable battery failure.
- Using the vehicle for crop spraying applications. This vehicle does not offer protection against harmful substances. Always use personal protective equipment if you decide to use this vehicle for crop spraying or other applications that require the use of hazardous substances.

4. PRELIMINARY WARNINGS

Adapt the speed of the vehicle to the terrain. When driving downhill, use the short LOW gear and keep the speed as low as possible, gently applying the brakes without locking the wheels. Under no circumstances should you perform manoeuvres with a slope / elevation or lowering greater than 15%. If you need to tow your vehicle, make sure the towing vehicle has sufficient drag and braking capacity, use a tow bar or a sufficiently long cable and do not go any faster than 10 km/hr.

All technical and mechanical repairs must be carried out by an authorised **CORVUS** garage.



DANGER

The electric motor and other components can reach high temperatures and take time to cool down once the motor has been switched off. Avoid handling or touching any hot components.

5. VEHICLE IDENTIFICATION (CHASSIS - ENGINE)

An identification plate is affixed to the battery showing details of the manufacturer, the model and the serial number.

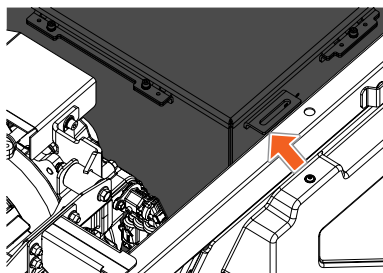

Your **CORVUS TERRAIN** has an **identification plate** which details: manufacturer, type approval, VIN, mass of the vehicle, maximum mass per axle (A1-A2) and towable mass (depending on type of braking and towing).

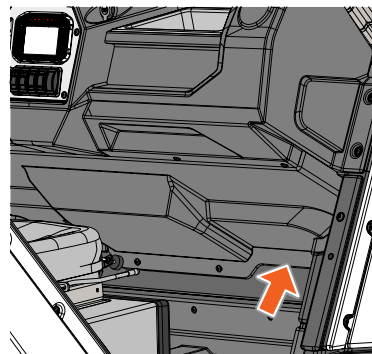

CORVUS INNOVA, S.L.
T1a
e13*167/2013*00205*04
UDXCTEX4FPLxxxxxx
1,400 kg
A-1: 650 kg
A-2: 950 kg

	T-1	T-2	T-3
B-1	450 kg	450 kg	450 kg
B-2	907 kg	907 kg	907 kg
B-3	-	-	-
B-4	-	-	-

The **vehicle identification number** is also stamped on the rear right-hand side of the chassis:

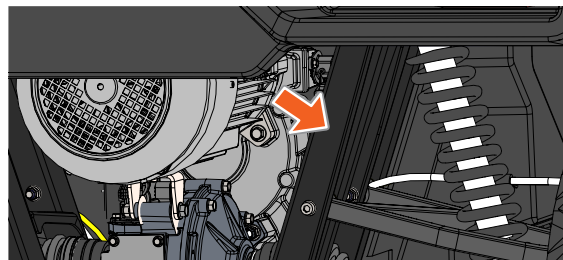

6. EXTERIOR COMPONENTS

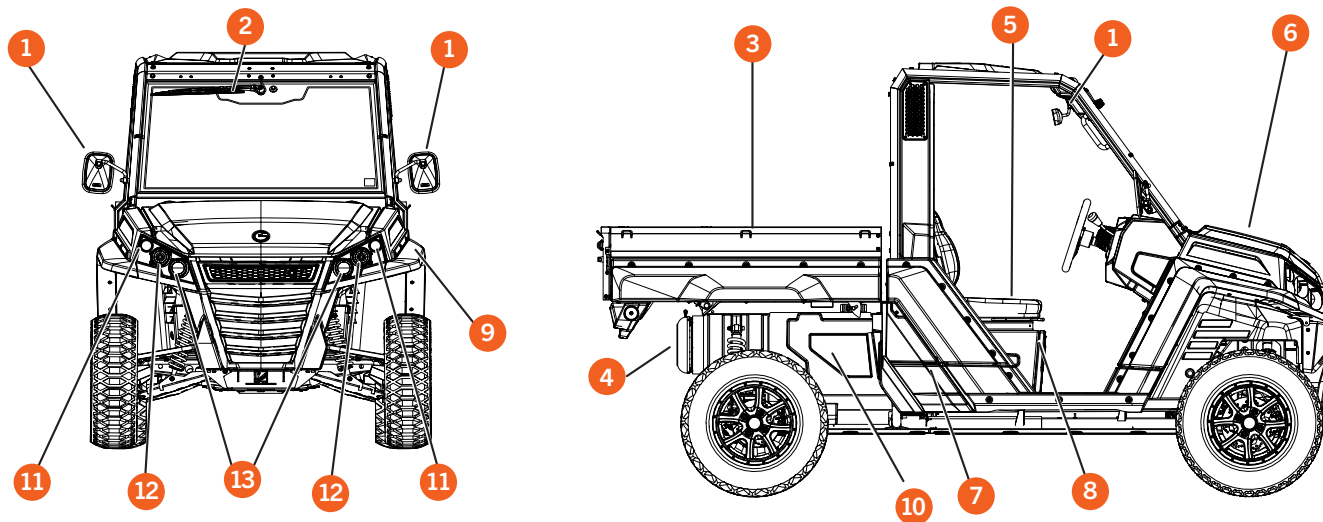

1. Rear-view mirrors
2. Windshield wiper *
3. Cargo box
4. Engine
5. Driving seat
6. Front hood
7. Spray suppression device / Side storage compartments

8. Inner storage compartments *
9. Battery charging cap
10. Battery and peripherals
11. Steering indicators
12. High beam
13. Low beam (short)

7. DRIVING SEAT

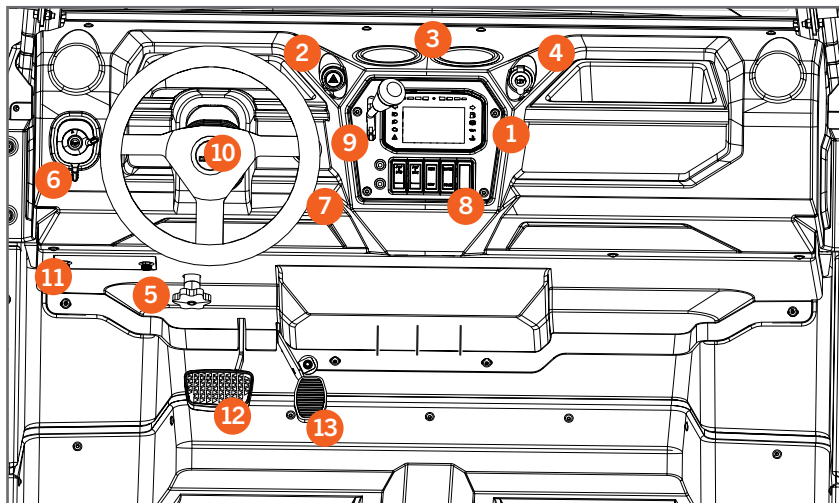

1. Multifunction panel.
2. Emergency light switch.
3. Cup holder.
4. 12V socket.
5. Steering wheel adjustment.
6. Switch for lights, turn signal lamps and horn.
7. Key ignition.
8. Instrument panel button panel.
9. Gear lever.
10. Steering wheel.
11. Fuse box.
12. Brake pedal.
13. Accelerator pedal.

8. LOCATION OF COMPONENTS

IGNITION KEY (1)

The lock is located to the right of the steering wheel and has three positions:

- OFF
- ON
- START



STORAGE COMPARTMENT KEY (2)*

The storage compartments are located under the seats.

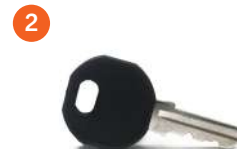

8. LOCATION OF COMPONENTS

LIGHT SWITCH

Located to the left of the steering wheel, with the following functions:

- **Turn signal lamps (1):** Move the lever to the right (right turn signal lamp) and to the left (left turn signal lamp).
- **Activation of the horn (2):** Press the red button in the centre.
- **Low beam (3) or high beam (4):** Move the lever to the required position.

The side, dipped-beam or side lamps will turn on automatically when you switch on the vehicle.

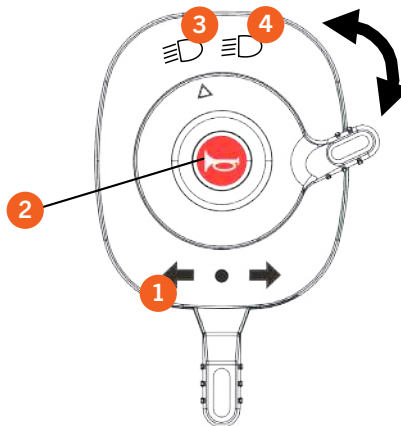

WINDSHIELD WIPER / WASHER BUTTON*

Located above the driving seat.

WINDSHIELD WIPER

- OFF Position (1) - Lower position.
- ON Position (2) - Central position.

- WINDSCREEN WIPER

- ON Position (3) - Upper position.

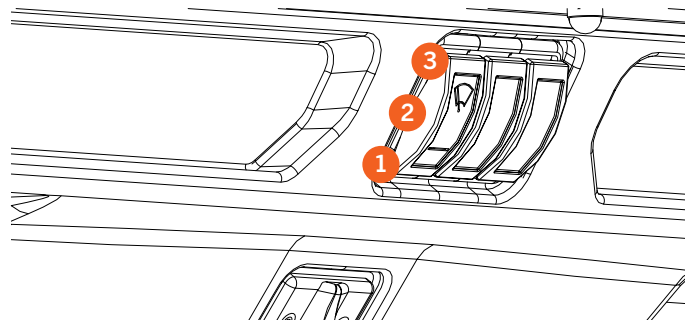

8. LOCATION OF COMPONENTS

INSTRUMENT PANEL

On the vehicle's instrument panel you can find:

1. Multifunction panel.
2. Multi-function panel controls.
3. Key ignition.
4. Emergency light switch.
5. 4WD driveline switch.
6. Rear differential lock switch.
7. Gear selector.
8. Power range selector.
9. Gearshift lever.

GEARSHIFT LEVER

The gearshift lever (9) is located in the centre the instrument panel.

It has 3 positions:

- (F) - FORWARD
- (N) - NEUTRAL
- (R) - REVERSE

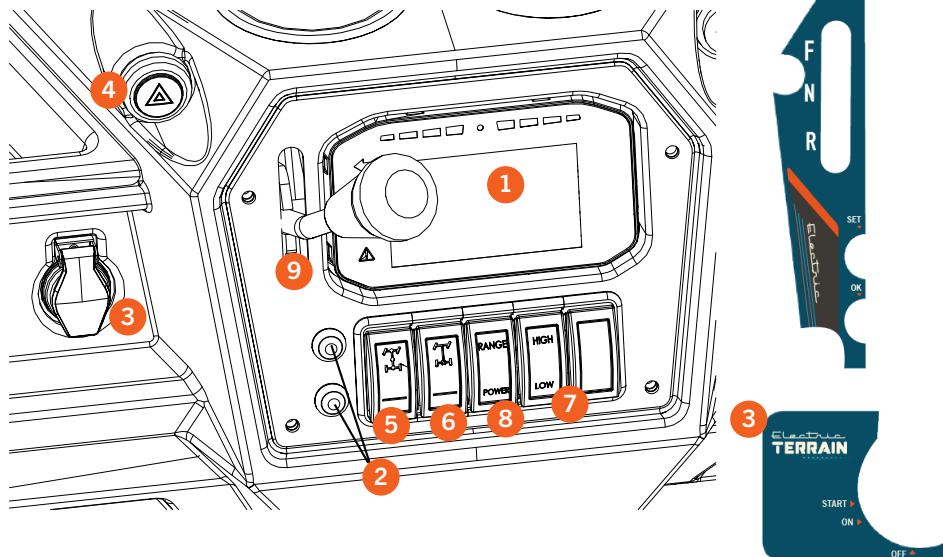

! Do not shift into reverse if the vehicle is not completely stopped, as it may cause accelerated wear or even breakage of the gearbox. Before driving in reverse, be especially careful and ensure that there are no people or obstacles in the area. When it is safe to reverse, do so slowly. Avoid sharp turns and apply the brakes gently to stop.

8. LOCATION OF COMPONENTS

2WD / 4WD DRIVELINE SWITCH

Located in the centre of the instrument panel.

It has 2 positions:

2WD: 2-wheel drive transmission -rear wheel drive- (1).

4WD: 4-wheel drive transmission (2).

REAR DIFFERENTIAL LOCK SWITCH

Located in the centre of the instrument panel.

It has 2 positions:

OFF: Rear differential unlocked (3).

LOCK: Rear differential locked (4).



THE 4WD AND THE DIFFERENTIAL LOCK MUST BE DEACTIVATED WHEN NOT REQUIRED.

EXCEEDING 20 KM/H WITH THE DIFFERENTIAL OR 4WD ENGAGED MAY CAUSE THE VEHICLE'S GEARBOX OR DIFFERENTIAL TO BREAK.

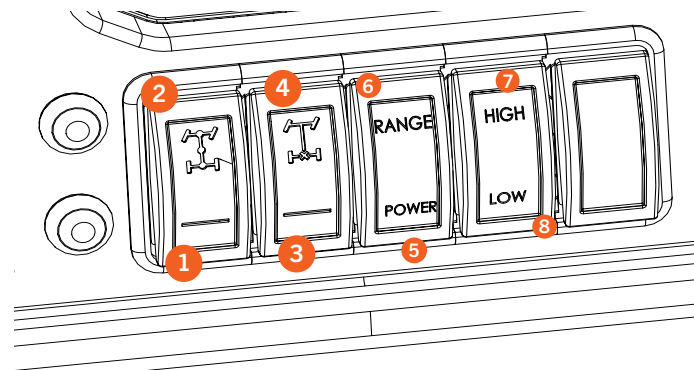

To minimise component wear, we recommend that you engage the 4WD and lock when the vehicle is at a complete standstill. **NEVER** engage the 4WD and lock when the steering is turned. Do not use the 4WD and lock on paved roads.

Remember to service the 4WD actuator and gearbox as indicated in the Service Chart (p. 49) to avoid premature deterioration.

8. LOCATION OF COMPONENTS

GEAR SELECTOR

The gearshift lever is located in the centre of the instrument panel and must be in neutral to change gear.

It has 2 positions:

L- LOW (7).

H - HIGH (8).

! Do not change gear if the vehicle is not completely stationary, as this can lead to accelerated deterioration or even breakage of the gearbox.

POWER RANGE SELECTOR

It is located on the instrument panel.

It has 2 positions:

RANGE: For smoother driving and to save power (6).

POWER: For when you need power - the battery will drain more quickly (5).

! Driving in **POWER** mode may rapidly reduce the battery charge level.

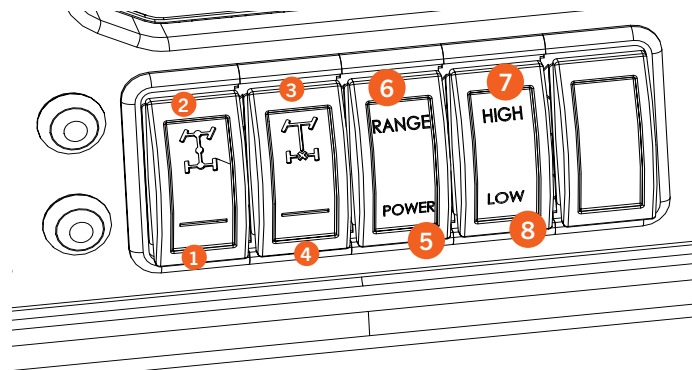

8. LOCATION OF COMPONENTS

PARKING BRAKE

The parking brake is engaged by means of a lever located on the left-hand side of the driver seat. Always apply the service brakes before engaging the parking brake.

It has 2 positions:

ON: Engage the parking brake by pulling the lever up firmly.

OFF: Lift the lever up slightly, push on the lock button and pull it down.



DO NOT apply the handbrake from outside the vehicle, as the lever may bend and damage bodywork components.
NEVER apply the handbrake when the vehicle is in motion, as this could lead to an accident.

The **AUDIBLE WARNING DEVICE** will activate in the following situations:

- If the vehicle does not detect anyone in the driver seat and the handbrake is not on.
- If any gear other than neutral (N) is engaged and the handbrake is on.
- If the vehicle's battery charge is low

- If there is an engine failure.
- If the temperature of the engine or the peripherals is high.
- If the auxiliary battery is not charging properly.
- If the vehicle detects a problem with the battery.
- To indicate that the vehicle has started correctly and is ready to move.

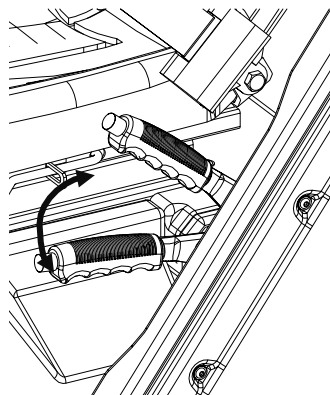

8. LOCATION OF COMPONENTS

REAR-VIEW MIRRORS

The vehicle is equipped with two rear-view mirrors (1), one on each side, and a third one on the inside in the centre* (2).

 Adjust the rear-view mirrors before driving to ensure maximum visibility.

 Do not adjust the rear-view mirrors while driving.

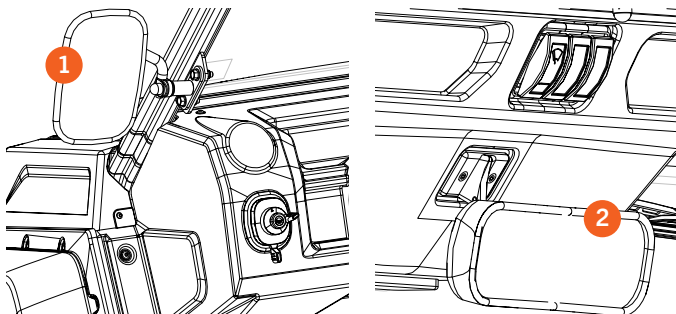

SAFETY BELTS

The safety belts are two-point belts and have a cam to release them.

 Adjust the safety belts before driving to ensure maximum safety in the event of an accident.

 Always drive with the safety belts correctly fastened. Do not adjust the belts while driving.

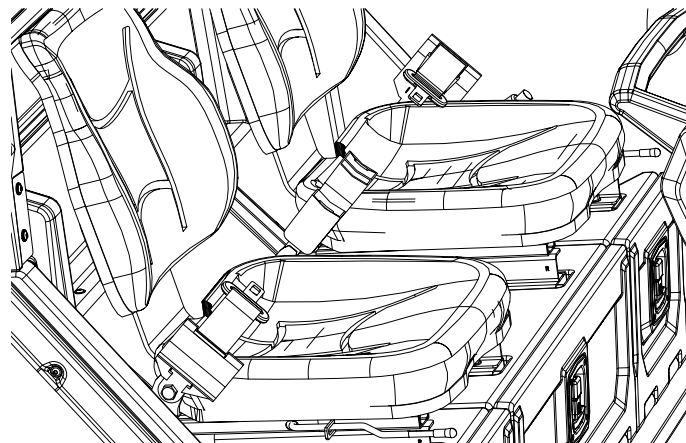

8. LOCATION OF COMPONENTS

STEERING WHEEL ADJUSTMENT

There is an adjustment knob under the steering wheel that allows you to move the position of the steering wheel along the vertical shaft for a more comfortable driving position. To do this, follow these steps:

1. Turn the knob counter-clockwise (A)
2. Place the steering wheel in the most comfortable driving position (B)
3. Turn the knob clockwise to re-tighten the steering wheel (C)

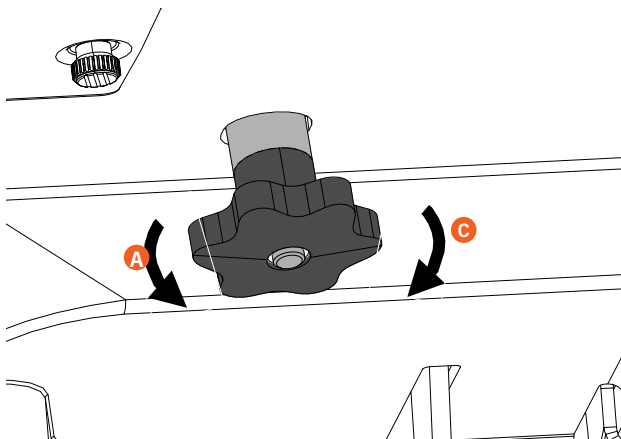

⚠ Do not adjust the steering wheel while driving; always do so before you start driving the vehicle.

Check the adjustment knob before you move off and tighten it firmly if necessary to prevent unwanted steering wheel movement while driving.

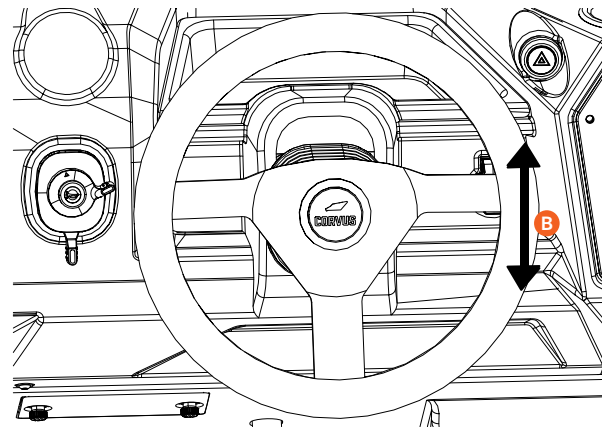

8. LOCATION OF COMPONENTS

LUGGAGE COMPARTMENT HOOD

To **open** the hood of the vehicle, you need to do the following:

- 1 - Press the button located on the hood (1).
- 2 - The hood will rise a few cm.
- 3 - Tilt the hood backward as far as it can go.

To **close** the hood of the vehicle:

- 1 - Lower the hood (2) slowly, without closing it.
- 2 - Press with both hands on the area around the logo to anchor it.



When closing the hood, do not let it drop. This could cause injury to you or others.

Before driving off, make sure it is completely closed.



Do not store flammable materials in any of the compartments.
Do not drive the vehicle with the hood open.

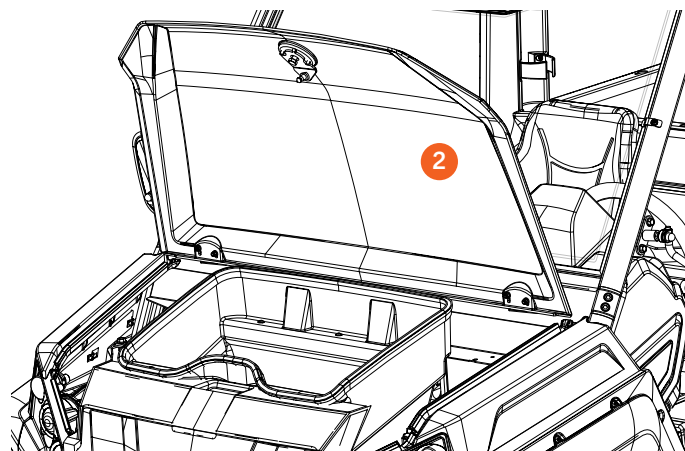
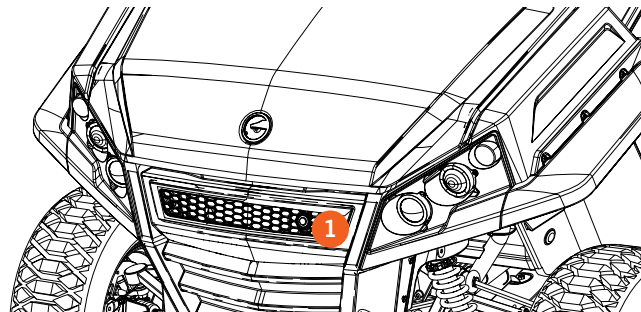

8. LOCATION OF COMPONENTS

CARGO BOX

The cargo box has a rear door (1) for easier loading and unloading of materials.

Opening the rear door:

- The door has two side bayonet levers (2).
- Grasp the door by the centre and open the two bayonet levers, one after the other.

 **Avoid opening both bayonets at the same time to avoid damaging the rear door or the structure of the cargo box.**

 **Sitting on or leaning against the tailgate is prohibited. This element is not designed for this purpose.**

 **NEVER lift the cargo box fully loaded. Doing so could cause the box to rise up unexpectedly or aggressively, which would break the springs and could cause serious injury to the operator.**

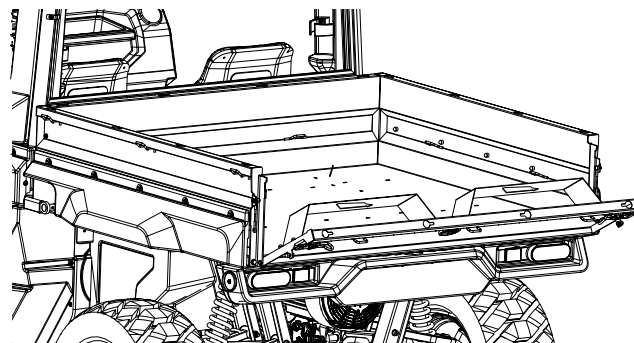
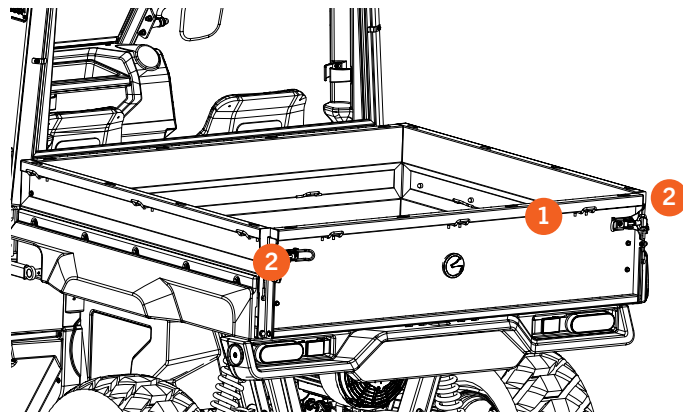

8. LOCATION OF COMPONENTS

TILTING THE CARGO BOX

To tilt the cargo box, proceed as follows:

- 1 - Turn the lever (1) clockwise.
- 2 - The box will be unhooked.
- 3 - Tilt the box up. The box has two shock absorbers (2) that make it easy to tilt it and prevent recoil.

- ! - An overload (max. 300 kg) can make the vehicle unstable and may lead to an accident.
- Place the load as far forward as possible.
- Place a mesh or a tarpaulin over light or volatile loads.
- Use straps to secure the load to prevent it moving in the box.
- The box has interior hooks (3) for fastening purposes.
- If driving on uneven or unstable terrain, reduce speed to avoid movements that may make you lose control.
- Make sure that the load does not protrude from the sides of the transport box.
- Remember that the heavier the load, the longer it will take to brake the vehicle.
- Keep any fluid tanks under control and make sure they do not move around inside the box.

- ! **NEVER** carry a passenger in or on the cargo box. Do not lift the cargo box when it is loaded. Doing so could pose a risk to the operator or even cause the vehicle to overturn. First unload the heavy load through the rear door.

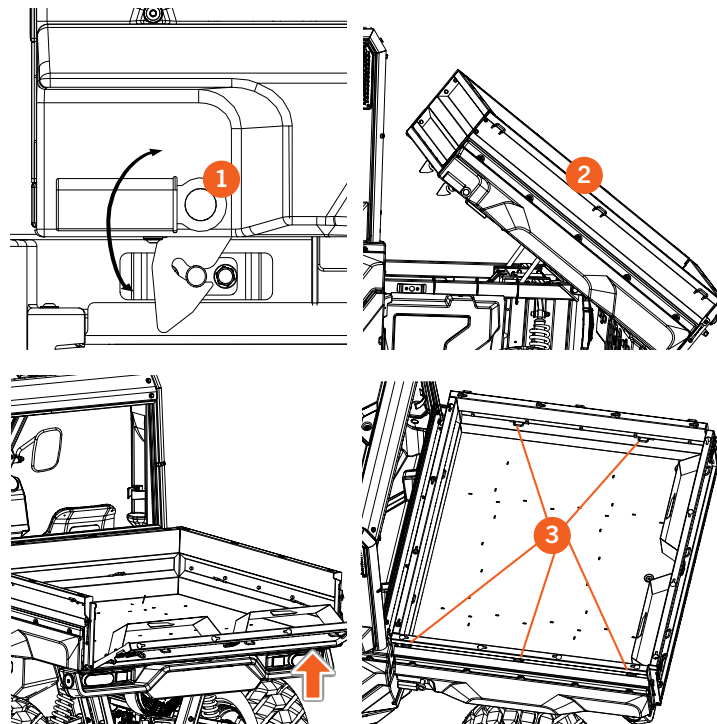

8. LOCATION OF COMPONENTS

UNLOADING THE BOX

Please follow the procedure below to unload the cargo box safely:

1. Park the vehicle on a straight and level surface and apply the handbrake.
2. Open the rear door and unload all or most of the load. Only lift the cargo box if you are absolutely sure you can lift it. Do not lift it with a load.
3. Once you have unloaded it, lower the cargo box and put it in place.

NEVER LIFT THE CARGO BOX FULLY LOADED. DOING SO COULD CAUSE THE BOX TO RISE UP UNEXPECTEDLY OR AGGRESSIVELY, WHICH WOULD BREAK THE SPRINGS AND COULD CAUSE SERIOUS INJURY TO THE OPERATOR.

ALWAYS UNLOAD THE VEHICLE ON A LEVEL SURFACE TO PREVENT THE VEHICLE FROM OVERTURNING.

NEVER DRIVE THE VEHICLE WITH THE CARGO BOX RAISED UP OR THE REAR DOOR OPEN.

**PLACE A MESH OR A TARPAULIN OVER LIGHT OR VOLATILE LOADS.
USE STRAPS TO SECURE THE LOAD TO PREVENT IT MOVING IN THE BOX.**

MAKE SURE THAT THE LOAD DOES NOT PROTRUDE FROM THE SIDES OF THE TRANSPORT BOX.

REMEMBER THAT THE HEAVIER THE LOAD, THE LONGER IT WILL TAKE TO BRAKE THE VEHICLE.

KEEP ANY FLUID TANKS UNDER CONTROL AND MAKE SURE THEY DO NOT MOVE AROUND INSIDE THE BOX.

NEVER DRIVE WITH A PASSENGER IN OR ON THE CARGO BOX, THIS COULD CAUSE SERIOUS INJURY OR EVEN DEATH TO THE PASSENGER. PASSENGERS MAY ONLY RIDE IN THE PASSENGER SEAT.

DO NOT PLACE HEAVY LOADS ON THE REAR DOOR, THIS COULD MAKE IT COLLAPSE.

CHARGING THE BATTERY

The charging point (1) of the battery is located on the left side of the vehicle above the rear fender.

The charger is a type 2 (“Mennekes”) as shown in image (1).

To charge the battery, you will need access to a power outlet compatible with your charger. The circuit must also be suitable for charging electric vehicles. Ensure it is properly grounded and meets all local codes and ordinances. If you are unsure whether the circuit is suitable, consult a qualified electrician.

8. LOCATION OF COMPONENTS

To charge the battery you must first:

1. Park the vehicle on a level surface and apply the handbrake.
2. Turn the vehicle off.
3. Open the charging point (1)
4. Connect the charging cable.

The following information will be displayed on the multifunction panel (2) once you have connected the plug.

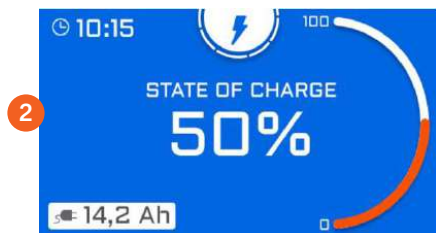

Do Not Charge The Batteries By Any Method Other Than The Corvus Charging Point.



Check The Charging Point Daily To Avoid Any Build-Up Of Water Or Other Foreign Matter That Could Damage The Contacts.

Check That The Charging Cable Is In Good Working Order Before You Connect It To Your Vehicle. A Broken Charging Cable Could Damage Vehicle Components.

Charge In A Dry Place At A Suitable Temperature. Never Above 40°C

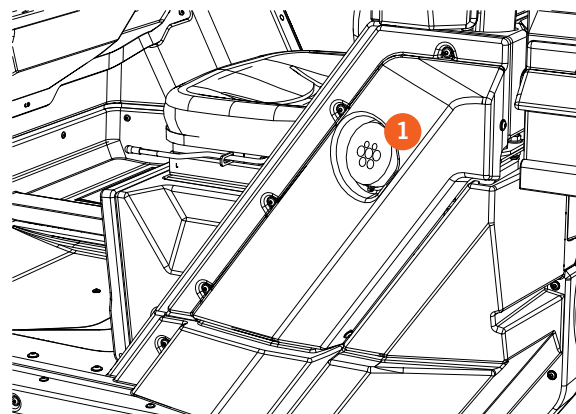

8. LOCATION OF COMPONENTS

CARGA DE BATERÍA

The Battery Controller Is Calibrated The First Few Times The Battery Is Charged. This May Result In An Incorrect Battery Percentage Being Displayed. If The Problem Persists, Please Contact Your Corvus Service Centre.

If The Battery Temperature Falls Below 0 °C And You Do Not Have Thermal Blankets, You Will Not Be Able To Charge The Battery Until The Temperature Rises Above This Temperature. If You Do Have Thermal Blankets, When You Connect The Battery Cable, It Will Start To Heat Up And Charge Once It Has Reached The Required Temperature.

It Is Not Possible To Charge The Battery If Its Temperature Is Below -14 °C.

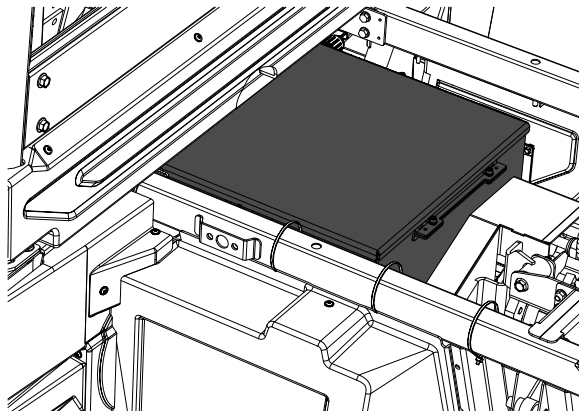





The battery is located beneath the cargo box, inside a protective casing.

The elements required for charging, such as the converter and the charge management system, can be found next to the battery.

To clean the battery area, use low-pressure water and a cloth, taking care to avoid the connectors and grommets. Under no circumstances should you use high-pressure water for cleaning.

Do not open batteries or perimeter controllers for any reason no matter how justified it may seem, please contact your nearest Corvus Service Centre.

-  **DO NOT** charge the batteries by any method other than the **CORVUS CHARGING POINT**.
-  Handling batteries can result in electrical failure, component rupture or fire.
-  Handling battery management systems may result in electrical failure, component breakage or fire.
-  **DO NOT WASH THE BATTERY COMPONENTS WITH HIGH-PRESSURE WATER.**
-  Do not perform maintenance tasks or attempt to repair battery components. There are high-voltage system components that cannot be repaired by the user. Maintenance and repair of high-voltage components should always be carried out by a qualified technician.

8. LOCATION OF COMPONENTS

TRAILER

The vehicle is fitted with a towbar at the rear of the vehicle. It is important that you are aware of the load limitations of the towbar; for this purpose, there is a type approval plate with the following information.

MODEL: CORVUS TERRAIN EX4

MAX towing capacity on trailer WITH inertia brake	907 kg
Max. vertical towbar load (1)	240 kg

- ! Do not pull or tow objects from any point on the vehicle other than the pulling winch (if fitted) or from the tow points provided (one at the rear with a towbar and one at the front).

Never carry passengers on the trailer.

When driving the vehicle, avoid sharp turns or aggressive driving. Accelerate gradually and bear in mind that the braking distance will be affected by the load on the trailer.

Do not exceed 16 km/h when towing a load and drive the vehicle with the low gear (L) engaged.

Do not drive on steep or dangerous terrain when towing a load. If you have to drive on difficult terrain, reduce your speed considerably and pay attention at all times to elements that pose a potential hazard to your safety.

When parking a vehicle with a trailer it is important to park on a horizontal surface. Do not park on a slope or leave the vehicle parked with a gear engaged, as this will not prevent the vehicle from rolling downhill. Always apply the hand brake. To improve vehicle stability and reduce the effects of towing the load to a minimum, it is advisable to distribute the weight of the load between the box and the trailer, if possible.

- ! Secure the load on the trailer properly and ensure that the area between the trailer and the vehicle is free of anything that might damage the trailer or affect your driving.

On the top of the towbar there is a pineapple-like 7 pin electrical trailer connector with a maximum power rating of 150W. Exceeding this can cause serious damage to the electrical system and should not be exceeded under any circumstances. This maximum power will be even lower if anything is connected to any of the vehicle's auxiliary sockets.

You can only tow a vehicle that is equal to or smaller in size and weight than your Corvus vehicle. When towing a disabled vehicle, place its transmission in neutral. Incorrect towing may cause loss of control or damage to one or both vehicles.

- ! Always stay clear of the area between the vehicle and the towed object while towing. Failure to follow these instructions can result in serious injuries or even death.

The above list of hazards and risks does not include all possible hazards and risks that may occur. Be cautious.

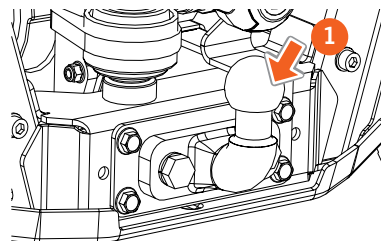

8. LOCATION OF COMPONENTS

INSIDE STORAGE COMPARTMENTS

You will find three storage compartments under the seats.
You must use the specific key to open them (2, page 10).

- 1 - Insert the key into the lock.
- 2 - Lift the handle.
- 3 - Turn the knob to the left or right.
- 4 - Slowly lower the cover.

To close it, carry out the same steps in reverse.



NEVER drive the vehicle with the storage compartments open.
Do not drive the vehicle while the storage compartments are being handled.
Do not store flammable material inside the storage compartments.



Although the storage compartments are water resistant, they are not completely waterproof: do not store any objects in them that you do not want to be affected by humidity.

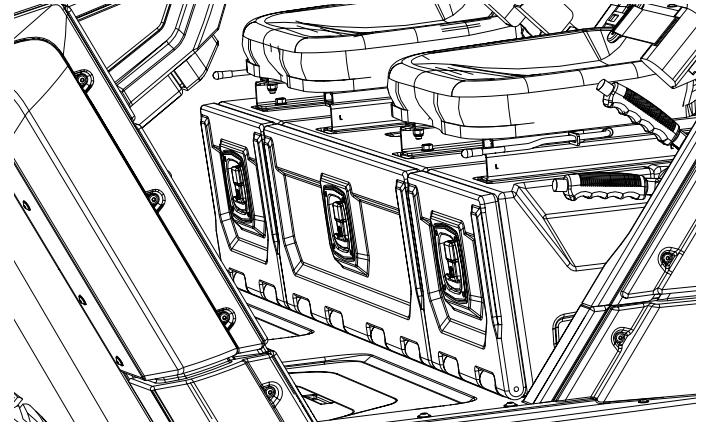

9. SPECIFICATIONS

ENGINE

Engine type	AC induction at 48V
Battery	Lithium-ion 15 kWh
Torque	150 Nm (rated)
Power	13 kw
Maximum speed	In Low: 25 km/h. In High 40 km/h
Transmission mode	On-demand 2WD or 4WD drive-line with lockable rear differential.
Transmission	F-N-R shift lever. H-L selection button

LIQUIDS

Brake fluid ¹	DOT-4
Transmission oil	SAE 80W-90 GL5 EP Quantity: 1.2 L
Differential oil	SAE 80W-90 GL5 EP Quantity: 0.5 L
4WD actuator oil *	SAE 80W-90 GL5 EP Quantity: 0.7 L

DIMENSIONS

L x W x H	3414 x 1656 x 1973 mm
Wheelbase	2238 mm
Ground clearance	309 mm
Curb weight	860 kg
Towing displacement	In Low: 907 kg. In High: 450 kg
Max. total load capacity	620 kg

CARGO BOX

Dimensions (L x W x H)	1340 x 1203 x 300 mm
Material	Steel
Load capacity	300 kg

BATTERY

Generator	37 A
Battery charger	3 Kw (AC)
Running time	RANGE mode: 100 km (depending on usage) POWER mode: depending on usage

1.- Cold weather countries should adjust the antifreeze solution to suit the temperature.

9. SPECIFICATIONS

CHASSIS

Front tire	6x9. R14
Rear tire	26x11. R14
Wheel rims	14" steel
Lights	High-intensity 60W halogen lights
Turning radius	4.42 m
Front and rear suspension	Independent double wishbone suspension (both). 287 mm travel
Front brakes	Hydraulic dual-piston disc brakes
Rear brakes	Hydraulic disc brakes
Parking brake	Yes
Protections	Underbody protection
Coupling	2" front adapter and rear ball
No. passengers	2

APPROVAL

Type	EU T1a
------	--------

CABIN

Windshield	Front *	Fixed laminate
	Rear *	Fixed tempered
Seats	2, separated	
Windshield wiper *	Upper centre part	
Safety belt	2-point	
Interior safety storage compartments	Beneath the seats	

10. MULTIFUNCTION PANEL

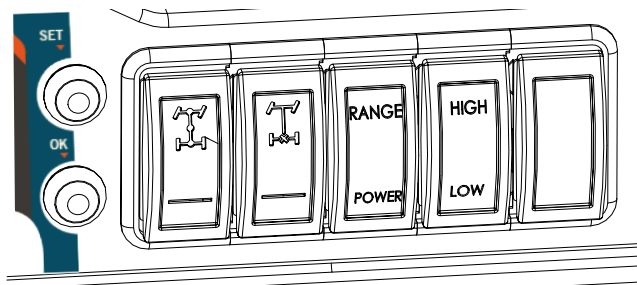

The multifunction device is water resistant but not waterproof. Do not wash it with water under pressure.

Do not leave the device in direct sunlight when the vehicle is not in use.

Avoid contact with fuel, degreasers or other chemical cleaners as they may damage the device. Remember to always pay attention to the road while driving.



10. MULTIFUNCTION PANEL

WARNING INDICATORS



Battery overheating:

The battery and/or any of the peripheral modules are above their safe operating temperature. If this happens, the vehicle will shut down until they return to operating temperature.

Whenever this warning indicator appears, please inform your nearest Corvus Service Centre.



Battery failure:

The battery and/or any of the peripherals have entered error or warning mode. The vehicle may shut down or slow down if this warning indicator appears.

Whenever this warning indicator appears, please inform your nearest Corvus Service Centre.



Charge connected:

This indicates that the charging cable is connected; if this warning indicator appears the vehicle will not operate.

If this warning indicator appears even though the charger is not connected, please contact your nearest Corvus Service Centre.

Please also contact your nearest Corvus Service Centre if this warning indicator does not appear during charging.



Engine overheating:

This warning indicator appears when the engine or the controller exceeds the maximum operating temperature. When it appears, the vehicle may shut down until the temperature is reduced.

Whenever this warning indicator appears, please inform your nearest Corvus Service Centre.



Engine failure:

This warning indicator appears when the engine or controller has entered error or warning mode. The vehicle may shut down completely or reduce its operating speed.

Whenever this warning indicator appears, please inform your nearest Corvus Service Centre.

10. MULTIFUNCTION PANEL

ON-SCREEN NOTIFICATIONS



The parking light will start flashing and a buzzer will sound if the speed is above 2km/h and the parking brake is engaged.



This notification will appear whenever the procedure to activate the vehicle is not performed correctly.

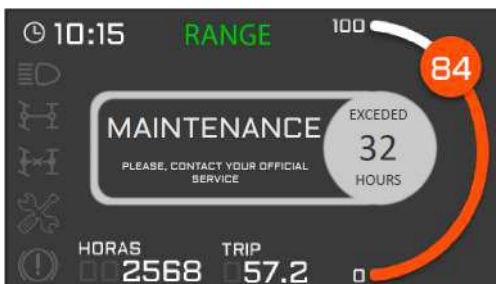

A maintenance message will be displayed for 5 seconds when the vehicle is activated.



When the 4WD is activated or deactivated, a notification will be displayed on the screen.

10. MULTIFUNCTION PANEL

ON-SCREEN NOTIFICATIONS



When the differential is activated or deactivated, a notification will be displayed on the screen.



When changing gear, this message will appear if you have not performed the process correctly. Always change gear by selecting N.



When changing driving mode while driving, the notification shown above will appear. Stop the vehicle and try again.

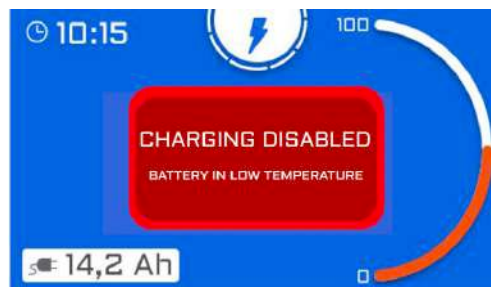

The following notification may appear during charging. If this happens, the vehicle cannot be charged until the temperature of the battery pack has risen.

10. MULTIFUNCTION PANEL

ON-SCREEN NOTIFICATIONS

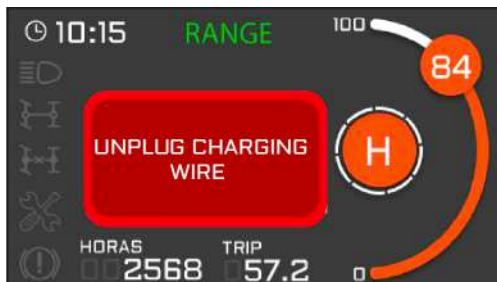

If you forget to disconnect the cable after charging and try to start the vehicle, the following message will appear on the display.

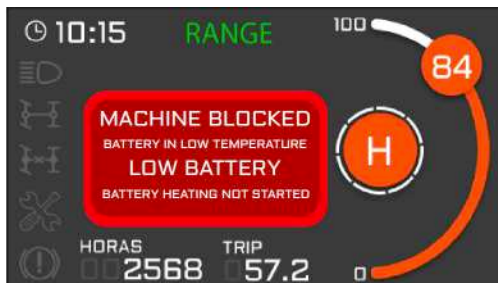

This message will appear if the battery charge is too low when the heater is activated.



When the battery is in use and the battery temperature is below the operating temperature (-14°C), these messages will appear on the display depending on whether or not the vehicle has a battery heater. If it does not, it will not be possible to use the vehicle until the temperature rises. If your vehicle does have a heater, wait with the key ON until the correct temperature is reached.

10. MULTIFUNCTION PANEL

ON-SCREEN NOTIFICATIONS



If this message appears, you should check the inverter area as something may be preventing the fans from working properly or there may be dirt in the area. If this is not the case, contact your nearest technical service.

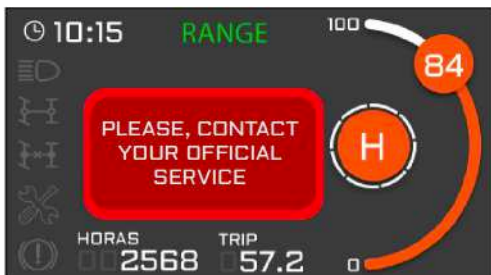

If this message appears on the screen, the vehicle has an inverter or battery failure. It will not operate and you should contact your nearest technical service.

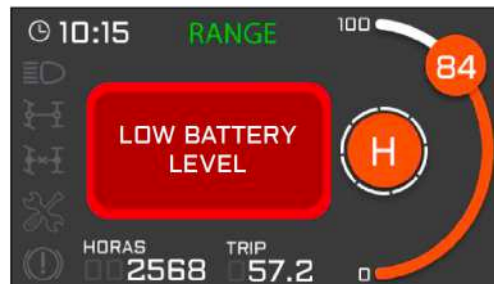

This message will appear for the first time when the battery drops to 20%. The buzzer will sound 4 times and it will disappear after a few seconds. This message will appear every 5% until the battery level drops to 5%. When this happens, the message will not disappear and the buzzer will sound every 4 seconds.

! The battery charge should not drop below 20% as it may go into deep discharge.

10. MULTIFUNCTION PANEL

FUNCTIONALITIES

- **Odometer**
After contact, press the OK button to switch between kilometres and hours.
- **TRIP**
The dashboard has 2 meter readings, either kilometres or TRIP: to switch between them just press the SET button.

If you want to reset the TRIP function, press and hold the SET button until the kilometres return to 0.

SETTINGS SCREEN

In this screen you can change the speed unit, the dashboard language, and the clock mode. To enter this mode, press and hold both the OK and SET buttons until the menu appears.

- **Speed units**
Accessing the menu will take you directly to the speed units; pressing SET will take you to the next setting section. Pressing OK takes you to the setting section; with SET you can switch between "kms" and "miles". To accept the change, press OK.

- **Language**
If you press the SET button when you access the settings menu, the language section will be displayed on the screen. By pressing OK you can access the setting, where you have to press the SET button to switch between the different languages. Once you have found your desired language, you need to press the OK button to accept the setting.
- **Changing the time**
To change the hour setting, press the SET button (each press of the SET button will add one hour). Press OK to accept the setting.

Then change the minute setting: each press of the SET button will add one minute. Press OK to confirm the time and exit.

MAINTENANCE SCREEN

The maintenance screen will appear for 2s when the vehicle is switched on if it requires servicing in less than 100 km or 10 hours.

To access the maintenance screen, make sure the vehicle is at a complete standstill and press the OK button for 2 seconds.

- **Maintenance reset**
Once in the maintenance page, press the OK and SET button until a confirmation screen appears: to accept press the OK button, to cancel press the SET button.

10. MULTIFUNCTION PANEL

CHARGE SCREEN

When the vehicle is connected to the charging point and the vehicle is switched off, this display will appear on the multifunction panel.

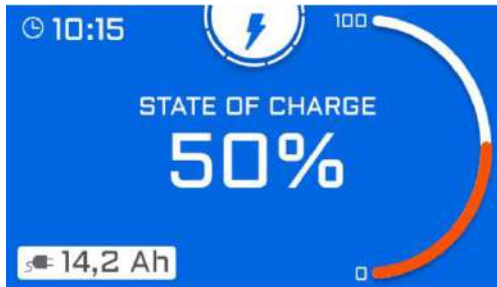



USAGE INFORMATION

II. DAILY INSPECTION BEFORE DRIVING

 These controls can actually be performed very quickly, it is a question of habit. the user knows to what use the vehicle has been subjected the last time it was used and where to intensify this control. Respecting this set of controls implies greater security for the user and, undoubtedly, better and more economical maintenance of your vehicle.



Before driving, put the vehicle in horizontal position and perform the following controls:

Is the battery sufficiently charged?

Check your battery level on the multifunction panel (1) and make sure you charge the battery before each use.

Is the brake fluid reservoir level correct?

It is located beneath the hood, under the luggage compartment hood if there is one.

The container is translucent (2).

Its level must be between MIN/MAX; if necessary, add brake fluid.

 If the brake fluid level is outside the limits shown on the tank, check the thickness of the brake pads and make sure they have not reached their usage limit.

If the thickness is correct, fill up the brake fluid and make sure there is no leakage: if in doubt, go immediately to your CORVUS dealer, they know what to do in each case.

This can affect your safety.

NEVER drive the vehicle if the brake fluid level is low.

Check the level regularly and carry out maintenance as indicated in the Service Chart (p. 40).

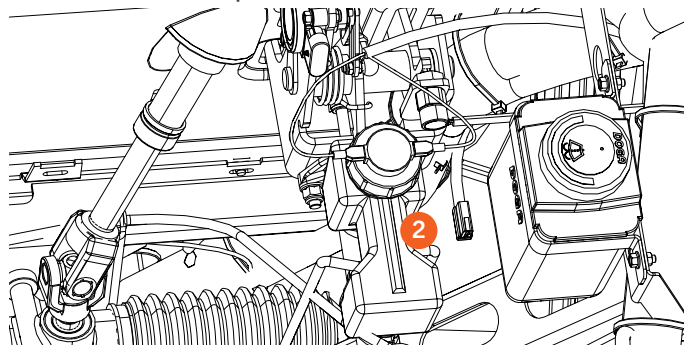

II. DAILY INSPECTION BEFORE DRIVING

Have any wires come loose?

The batteries, their controllers and everything related to the engine can be found beneath the cargo box. To avoid electrical failures, it is important to check whether any wires have come loose or been damaged by foreign matter or by interference with other components.

If you do find any damaged or loose wiring, please contact your nearest Corvus Service Centre.

Is there any corrosion on the connections?

Check that the connectors are in good condition and that there are no signs of corrosion on the terminals. If you do find corrosion on the terminal, please contact your nearest Corvus Service Centre.



Do not under any circumstances disassemble the enclosure of any of the controllers, inverter or batteries.

A loose or damaged cable could interfere with the proper operation of the vehicle, and may even cause irreversible damage or fire.

Connecting or disconnecting a battery terminal incorrectly can lead to a catastrophic battery failure.

Is the battery in good condition?

It is important to check that the battery casing is in good condition and that there are no dents or scratches.

Check that the battery and engine mounts are in good condition.

Do the brake discs look okay?

Any important scratches, cracks, excessive wear, etc. can be easily spotted.



Check that the discs are at least 3.5 mm thick on the front and rear wheels.

Go immediately to your CORVUS dealer if you don't know what to do in each case. This can affect your safety. You should not drive the vehicle.

II. DAILY INSPECTION BEFORE DRIVING

Are the front and rear brake pads in good condition?

Check the thickness of the remaining lining, ensuring that the thickness of the lining is not less than 1.5 mm. If it is, contact your CORVUS dealer to replace them.

Check that the brake pads do not rub against the discs when the hydraulic brake pedal or parking brake lever is deactivated.



NEVER drive a vehicle with worn brake pads. Brake pads in this condition lose their effectiveness and could pose a serious risk to your safety.

Visit your CORVUS Service Centre to have the brake pads replaced immediately.



Clean the area around the wheel spindle and the brakes regularly to prevent the build-up of mud and other foreign matter. Allowing these to build up could lead to loss of brake effectiveness and rapid deterioration of components.

Do the commands feel okay to the touch?

The brake pedal, accelerator pedal, gearshift lever, differential lock lever, 2WD/4WD driveline level, hand brake lever, light panel, ignition system, horn and indicators. All these commands and control elements have their own characteristic functioning and touch, any change indicates an abnormality or damage. Nobody knows your vehicle better than you do, if you appreciate any changes, go immediately to your CORVUS dealer.

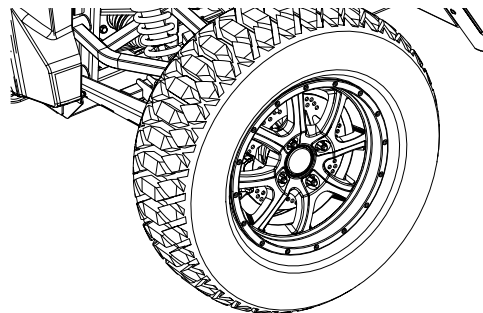

Are the tires in good condition?

If in doubt, ALWAYS check the pressure level. If the problem persists, or is repeated, there may be a leak: see your CORVUS dealer.

Recommended front/rear pressure:

- 1.0 bar (empty vehicle).
- 1.5 bar (vehicle at full load).

Tire tread wear limit: 3.5 mm deep.

Improper tire maintenance can cause loss of vehicle control while driving and lead to an accident, potentially causing serious injuries or even death. Use only the specific size and type of tires for this vehicle and always follow the manufacturer's maintenance instructions.

II. DAILY INSPECTION BEFORE DRIVING

Is there the risk of any element falling off?

Fenders, side covers, tank, mud flaps, etc. If there is any such risk, you should try to attach it or remove it so that it does not fall off, for the sake of your safety. Visit your CORVUS dealer to have it repaired.

Are there any leaks?

Visually check for leaks, assessing them on the basis of their location, amount and the product that is leaking (be aware of the danger of fire). Always go as quickly as possible to your official CORVUS distributor or dealer.

Do the safety belts work properly?

The safety belt will not function properly if the buckle or the strap of the belt are dirty or damaged. For this reason, always keep the buckle and the strap of the safety belts clean, because otherwise, the tongue of the belt will not click into place correctly.

Regularly check the safety belts to ensure that:

- They are not damaged.
- They are not in contact with sharp edges.
- They are not entangled.

In case of doubt or anomaly, go to your CORVUS dealer.

Does the lighting and signalling system light up properly?

Regularly check all the bulbs of the lighting and signalling system are working properly. If you detect that any of them have burned out, replace them immediately.



Regularly review the tightening torque of the bolts of the vehicle, paying special attention to the suspension, bushings, wheel spindles, driveline, steering and brakes.

NEVER drive without a bolt or a nut.

The lighting and signalling system are important safety measures: you should never drive the vehicle without either of them.

Daily checks can prevent breakdowns and accidents.

II. DAILY INSPECTION BEFORE DRIVING

Is the vehicle clean?

Proper vehicle hygiene is important to ensure that the battery or engine system does not overheat. Many of the vehicle's components require air for proper cooling and a build-up of mud, dust or other foreign matter can have a negative effect.

The accumulation of mud on the vehicle's moving parts could have a negative effect on their performance. You should regularly remove any mud from the vehicle and prevent it from solidifying.

 **Do not clean the battery or engine area with high-pressure water, as this could irreversibly damage the systems.**

If you notice that any of the electronic components have been damaged, do not wash the vehicle but contact your nearest Corvus Service Centre.

It is important to keep the area around the discs, pads and wheel spindles clean. Do not allow mud or external elements to accumulate over long periods of time. These elements can affect the performance, effectiveness and life of the materials.

DAILY CHARGE

Perform the operation described on page 22.

It is advisable to charge the vehicle every day, even if the battery has not been fully discharged. This will help to extend the life of the batteries.

The battery level should not be allowed to fall below 20%.



You should perform at least one full charge cycle per month, even if the vehicle is not in use.

The battery should be charged in a dry environment with temperatures below 40°C - the ideal charging temperature is 25°C.

12. STARTING THE VEHICLE

To start your Corvus vehicle, please follow the steps below:

1. Sit in the driver's seat and fasten your seatbelt.
2. Check that the gearshift lever is in the N (Neutral) position.
3. Turn the key (2) to the ON position, the multifunctional panel will light up.
4. Press the brake pedal and turn the key (3) fully until you hear a beep. Do not press the accelerator pedal when starting the vehicle.

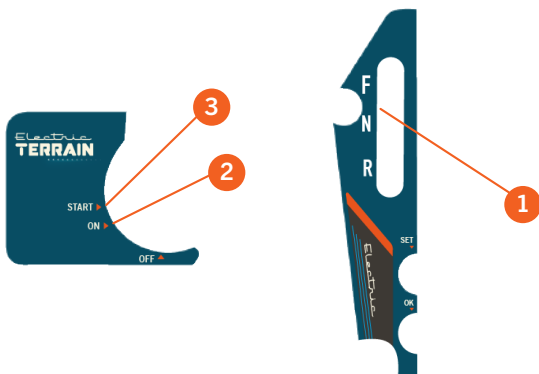

! Always keep the steps and the floor of the vehicle clean to avoid slippery conditions.

The gear lever should be operated with the vehicle completely stopped and the engine running at the lowest possible speed, without accelerating.

Failure to comply with this instruction can cause severe damage to the driveline.

Do not drive with the hand brake on.

Do not operate the hand brake to stop the vehicle. Doing so can cause serious damage to the braking system of the vehicle and can be dangerous. When moving into gear, accelerate gently, avoiding abrupt accelerations.

It is advisable to engage the 4x4 with the vehicle completely stopped to minimize wear on the components.

! Never attempt to get on or off the vehicle while it is in motion, nor jump off the vehicle. Always pay attention to the vehicle when getting on or off.

Do not use components such as hand grips while driving. This can cause involuntary movements of the vehicle.

13. USE OF THE 2WD / 4WD DRIVELINE *

 To minimise component wear, we recommend that you engage the 4WD when the vehicle is at a complete standstill.

It must **NEVER** be used on the road or on asphalt. The 4WD may only be used up to 20 km/h.

Failure to comply with this instruction can cause severe damage to the transmission system and the gearbox.

To **ENABLE 4WD driveline** perform the following steps:

1. Step on the brake pedal, without stepping on the accelerator.
2. Put the gearshift lever into NEUTRAL (N) - central position.
3. Press the switch to the ON position.

To **DISABLE 4WD driveline** perform the following steps:

1. With the vehicle completely stopped, step on the brake pedal, without stepping on the accelerator.
2. Put the gearshift lever into NEUTRAL (N) - central position.
3. Press the switch to the OFF position.

14. USE OF THE REAR DIFFERENTIAL LOCK AND UNLOCK*

 To minimise component wear, we recommend that you engage the lock when the vehicle is at a complete standstill.

It must **NEVER** be used on the road or on asphalt. The lock may only be used up to 20 km/h.

Failure to comply with this instruction can cause severe damage to the transmission system and the gearbox.

To **LOCK** the rear differential, perform the following steps:

1. With the vehicle completely stopped, step on the brake pedal, without applying the accelerator.
2. Disconnect the hand brake. Make sure that is completely disconnected.
3. Put the gearshift lever into NEUTRAL (N) - central position.
4. Press the switch to the lock position.

To **UNLOCK** the rear differential, perform the following steps:

1. With the vehicle completely stopped, step on the brake pedal, without applying the accelerator.
2. Ponga la palanca de cambios en NEUTRAL (N) -posición central-.
3. Press the switch to the unlock position.

15. DRIVING TIPS

GENERAL INFORMATION

- Keep your entire body inside the vehicle at all times while driving.
- Keep both hands on the steering wheel while driving.
- The front passenger seat can be occupied by a passenger while the vehicle is in use. Ensure the passenger remains alert.
- Ensure the passenger is properly seated and has their seatbelt fastened.
- Be aware of potential hazards that may enter the vehicle.
- Sudden or aggressive driving maneuvers, even in open areas and on flat surfaces, can result in loss of control and even vehicle rollover.

TURNING PRECAUTIONS

- Turning the steering wheel abruptly and at considerable speed could cause the vehicle to roll over. Drive proactively to avoid sudden turns. Sudden turns can be dangerous as they may cause loss of control, rollovers, and collisions.
- Avoid driving with the vehicle laterally inclined, and if you must do so, turn progressively. If the vehicle starts to slide downhill or feels like it might roll over, turn immediately downhill and stop. Maneuver slowly and carefully until you can drive straight downhill.
- Brake before turning and avoid sudden braking while turning.
- If you need to make turns with the car completely stopped or at low speeds, accelerate progressively

DRIVING ON SLOPES OR HILLS

- Try not to cross hills, but if unavoidable, drive slowly and do not proceed if you feel you might roll over. Engage all-wheel drive for slopes. Climb the slope in a straight line, maintaining constant speed and throttle.
- Avoid getting out of the vehicle on a slope. When unavoidable, be cautious. If leaving the vehicle unattended, place chocks on the rear wheels on the downhill side and keep children, pets, and other occupants away from the vehicle.
- Steep slopes could cause it to roll over. Avoid obstacles and changes in terrain that may cause the vehicle to lift on one side or slide. If the vehicle seems to start to roll over or slide, turn immediately downhill.
- Drive slowly, at a constant speed; if the vehicle stops moving forward, progressively apply the brake until completely stopped. Shift into reverse and let the vehicle slowly descend the hill or slope, applying the brake to maintain control.
- NEVER accelerate down a hill or slope, gently press the brake to maintain control.
- If the vehicle is inevitably going to roll over, keep your body entirely inside the vehicle, press firmly against the floor, and hold tightly to the steering wheel or the passenger grip.
- Do not attempt to stop the rollover with any part of your body.

DRIVING ON PAVED SURFACES

- As far as possible, try not to drive on paved surfaces.
- If you do need to drive on a paved road, turn gradually and drive cautiously.
- Do not engage the 4WD or the differential on paved roads.

15. DRIVING TIPS

DRIVING THROUGH WATER

- Avoid driving through water if not necessary.
- NEVER drive through fast-moving water, as it could cause you to lose control, be swept away, or even roll over.
- Before entering the water, choose your crossing point carefully, avoiding rocks or sudden drops. Always select gradual declines.
- Pay special attention and take care when performing these operations.
- Wet brakes may have reduced braking capacity. After exiting the water, test the brakes. Apply them lightly several times while driving slowly. The friction will help dry the pads.
- Do not enter water if it exceeds the height of the wheel hub.
- Do not drive through water at high speed, even if the depth is shallow.

HIGH-SPEED DRIVING

- Driving off-road vehicles to test the limits of their capabilities can be very dangerous for the driver, passenger, and those nearby. High-speed driving can lead to loss of control from impacts or abrupt landings, which can seriously injure occupants (even without rolling over or damaging the vehicle).
- Basic driving skills for this vehicle do not qualify the driver to drive safely at high speeds. Develop your skills gradually through training, practice, and experience with the various driving modes this vehicle offers and the terrain you are driving on.
- If you plan to use the vehicle for off-road competitions, you may need additional safety equipment. Check the rules applicable to your competition.
- High-speed driving can affect the battery's range. Ensure the battery is sufficiently charged for the intended travel distance.

DRIVING IN OR NEAR WOODED OR BUSHY AREAS

- Be cautious when driving near trees, particularly on narrow trails. Tree branches or bushes can enter the vehicle or strike and injure the occupants.

DRIVING ON ICE OR SNOW

- Always keep the vehicle's pedals free of snow and ice. Brake frequently to minimize the buildup of snow or ice on the brake pads, which can reduce braking performance.
- Never drive the vehicle on a frozen body of water unless you have verified that the ice can support the vehicle's weight. If the vehicle falls through the ice, it can result in serious injury or death.

DRIVING ON DUNES OR SANDY TERRAIN

- Take extra caution when driving on or near dunes. Stay alert to changes in the terrain and never crest a slope blindly. An obstacle, a sudden drop, or a person could be on the other side of the slope.

DRIVING IN LOW VISIBILITY CONDITIONS

- Take extra caution and drive slowly when there are low visibility conditions such as fog, rain, or lack of natural light..

15. DRIVING TIPS

REVERSE GEAR

- Before shifting to reverse gear, take special care to ensure there are no people or obstacles in the area. When it is safe to proceed, back up slowly.
- If you need to maneuver in a small space, make sure to come to a complete stop before shifting between forward and reverse gears and vice versa

UNFAMILIAR TERRAIN

- If you are not familiar with the terrain you are driving over, check to see if there are any hidden obstacles or anything that could be hazardous to your work.
- Drive carefully and always use existing roads.
- Drive with extra caution if visibility is poor.

DRIVING WITH A LOAD

- When driving with a **loaded box** or a trailer:
 - Reduce speed and drive in LOW (L) gear.
 - Avoid hills or slopes.
 - Load the box correctly and drive with extra care.
 - A load greater than 300 kg could pose a serious risk to the occupants of the vehicle, NEVER exceed this load in the box.

- When **towing** a load:

- Opere en marcha LOW (L) y no supere los 16km/h.
- Use a low gear and do not exceed 16 km/h when towing a heavy load.
- Do not drive aggressively when towing a load.
- Bear in mind that the braking distance and stability of the vehicle will be affected by the towed weight.
- Never park on a slope when carrying a load.
- Avoid driving over unfamiliar or difficult terrain; if you must do so, reduce your speed considerably and be alert to any potentially dangerous elements you may encounter.
- Spreading the weight between the load box and the trailer, where possible, can help to improve the stability of the vehicle.

ACTIONS IN CASE OF VEHICLE DAMAGE, IMPACT, OR ROLLOVER

- Do not continue driving if the vehicle may have sustained damage or has been involved in an impact or rollover. Driving the vehicle after damage or an impact/rollover can result in loss of control, rollover, or an accident, potentially leading to serious injury or death. If you cannot safely transport the vehicle on your own, contact a recovery and towing service.
- After any impact or accident, ensure that an Official Corvus Service inspects your vehicle for possible damage.
- Be proactive in case your vehicle may become damaged or disabled, especially in remote areas. Whenever you drive, plan ahead on how to get help and stay safe until assistance arrives.

16. CLEANING THE VEHICLE

Después de la conducción, compruebe si hay daños o suciedad en el vehículo, para asegurarse de que el vehículo pueda almacenarse y volverse a conducir de forma segura. Mantener limpio su vehículo puede alargar la vida útil de varios componentes.

To clean your CORVUS, perform the following steps:

1. Remove the underbody protector.
2. Use low-pressure water and a cloth or sponge.
3. Clean the vehicle from top to bottom, using soapy or specialised products if the area requires it.
4. Use a damp cloth to clean the battery area.
5. Rinse with low-pressure water, taking care not to let the electrical areas get wet.
6. Allow the vehicle to dry naturally or wipe it dry for a better finish.
7. Reassemble any parts you may have removed in step 1.



It is important to clean the vehicle frequently, especially the area around the wheel spindle, brake callipers and the inside of the underbody protector.

NEVER use high-pressure equipment to clean the vehicle. Avoid aiming the jet of water directly at the multifunction panel, bearings, air cleaner, switches, controls or any other electrical element.



DO NOT USE CORROSIVE, ACIDIC OR HIGHLY AGGRESSIVE PRODUCTS.

17. VEHICLE STORAGE

If you are going to store the vehicle for a prolonged period of time, please do the following:

- Clean the vehicle thoroughly and allow it to dry.
- Disconnect the main battery by using the switch between the seats (1).
- Treat all bright or zinc-coated parts with wax-based corrosion inhibitors, except for the brake discs, which are made of stainless steel and do not need protection.
- Check the tire pressure and inflate them to their maximum pressure of 2 bars.
- Disconnect the auxiliary battery.
- Cover the vehicle to protect it from dust and dirt.
- Store the vehicle in a dry place that is not subjected to important temperature changes.
- Charge the battery at least once a month.
- Do not let the battery charge fall below 20%. If this happens, the battery may go into deep discharge and you will have to contact your Corvus service to get it working again.





To turn on the vehicle again, after storage:

- Connect the auxiliary battery (having charged it previously).
- Reconnect the main battery.
- Fully charge the battery.
- Check the points in the section "Daily inspection before driving".
- Perform a brief test drive.



MAINTENANCE

18. SAFETY AND MAINTENANCE STANDARDS

-  - The battery electrolyte contains sulphuric acid. Protect your eyes, clothing and skin. Sulphuric acid is highly corrosive; in case of contact with eyes or skin, wash with plenty of water and go to a doctor immediately.
 - Batteries produce hydrogen, a gas that can be highly explosive. Do not smoke and avoid open flames or sparks near the battery, especially when you are charging it.
 - Clean the brake pads in a ventilated place, directing the jet of compressed air in such a way that you do not breathe in the dust produced by the wear and tear of the friction material. Although such dust does not contain asbestos, inhalation is nevertheless harmful.
-  - Use original CORVUS spare parts and lubricants recommended by CORVUS. Non-original or non-compliant spare parts can damage the vehicle.
 - Only use tools designed specifically for this vehicle.
 - Always use new gaskets, sealing rings and pins during assembly.
 - After disassembly, clean the components with non-flammable solvent or one with a low flammability point. Lubricate all working surfaces before assembly, excluding the conical couplings.
 - After assembly, check that all components have been installed correctly and that they work perfectly.
 - For disassembly, inspection and assembly operations, only use tools with metric measurements. Metric screws, nuts and bolts are not interchangeable with connecting parts with English measurements. The use of unsuitable tools and connecting parts may damage your vehicle.

19. SERVICE CHART

The maintenance requirements set out in this chart are simple and necessary for a good maintenance of your vehicle.

A: ADJUST / C: CHECK / L: LUBRICATE / R: REPLACE

ELEMENT		Daily	Interval		
			50 h	500 h	2000 h
Auxiliary battery	Check indicators	C			
	Check the auxiliary battery		C		
Electrical equip	Wiring		C (1)		
	Battery terminals and peripherals	C	A		
	Battery	C			
Gearbox, differentials and transmissions	Check gearbox and front/rear differential oil level			C	
	Replace gearbox and front/rear differential / 4WD actuator oil		R (3)	R (4)	
	Check transmission joint boots	C			
	Cardan gaskets	L			
Wheels and amortization	Wheel bearings		C		
	Nuts and studs of the wheel bolts		C		
	Suspension ball joints and mounting points		C		
	Tire pressure and wear	C			
General check	Absence of leaks and state of seals (1)	C			R (6)
	Check brake fluid level	C			
	Replace brake fluid		L		R (6)
	Lubricate the wheel spindles, cardan gaskets and ball joints				
	Check and clean underbody protection.	C		A	
	Hand brake cable				
Engine	Check condition of discs and pads.	C			
	Check overall condition and cleanliness	C			

(1) Perform more often if the vehicle is used intensively, in areas with a lot of dust, sand, snow, wet or muddy conditions. (2): Replace if necessary. (3): The first time. (4): 2nd time and from then on. (5): Or 1 year, whichever comes first. (6): Or 2 years, whichever comes first.

20. RAISING THE VEHICLE

The vehicle is equipped with an area at the front (1) and another at the rear (2) to facilitate its elevation.

! Before raising the vehicle, make sure the brake is fully on and that the surface is flat and completely horizontal.

! Do not perform any operation or service while the vehicle is being lifted.
Do not touch the vehicle or get into it until it is fully raised and secured, as this could destabilise the vehicle and cause it to overturn.

1. Chock the wheels on the opposite axle to the one being serviced to prevent the vehicle from moving during the process.
2. Mark off the work area and keep it free of other people's passage.
3. Place the base of the forklift in the area indicated in the vehicle.
4. Raise the vehicle slowly, checking that it is stable.
5. After lifting the vehicle with the hoist, never place any part of your body underneath it without properly securing it first.

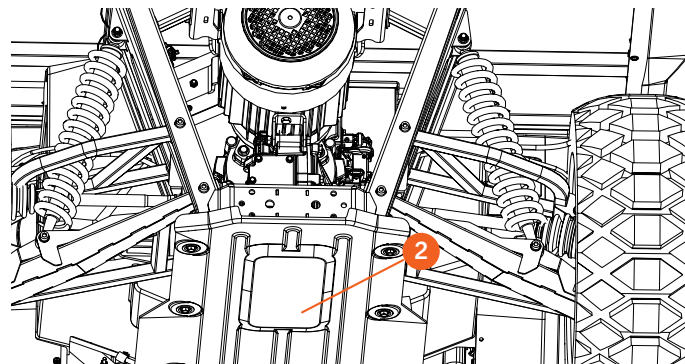
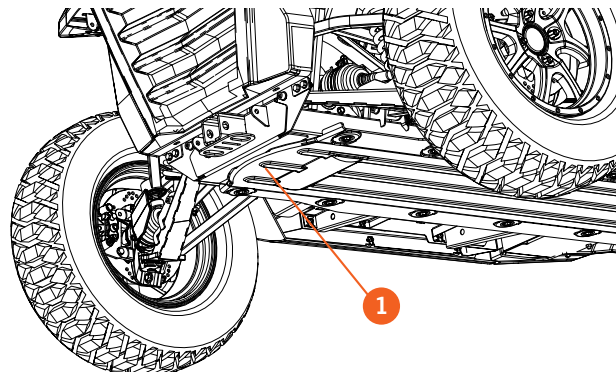

21. UNDERBODY PROTECTOR

DISASSEMBLY:

1. Remove the 12 screws (1) from the front underbody protector.
2. Uncouple the protector.
3. Remove the 8 screws (2) from the rear underbody protector.
4. Uncouple the protector.



Do not drive without the underbody protector, as this could jeopardise the integrity of important components such as the transmission.

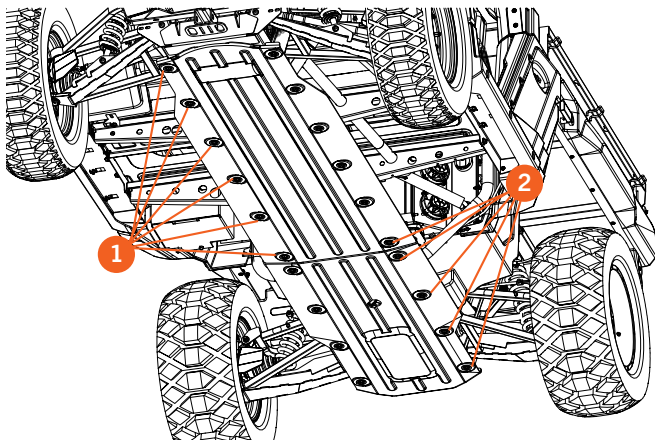

The underbody protector must be kept clean, both internally and externally. In order to be able to detect fluid leaks from the vehicle, to avoid rust due to trapped water, etc.

22. WHEELS

DISASSEMBLY:

1. Put the vehicle in a horizontal position.
2. Engage the parking brake.
3. Raise the area of the vehicle (front or rear) where the wheel you are removing is located (see page 50).
4. Remove the four screws (3) holding the wheel rim.
5. Remove the wheel.

Perform the above procedure in reverse for the installation.



NEVER drive without one of the wheel bolts, as this poses a great risk to your safety.



TECHNICAL INFORMATION Fastening torque for wheel nuts: 70 Nm.

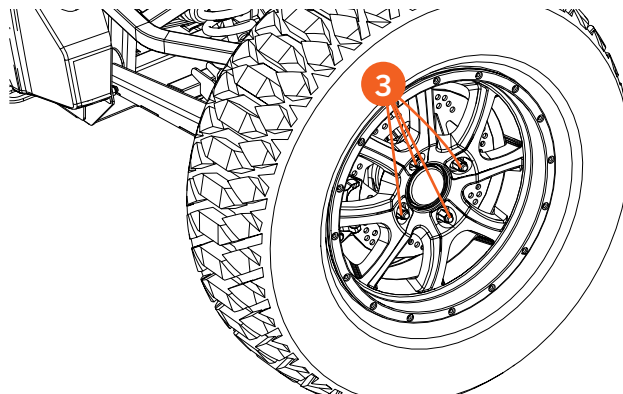

23. TRANSMISSION OIL (LEVEL CHECK)

The smooth operation and durability of the transmission essentially depend on the oil being kept at the optimum level and being changed periodically, as indicated in the Service Chart (page 49).

Checking procedure:

1. Put the vehicle in a horizontal position.
2. Remove the side protector (1).
3. Remove the level screw (2)*
4. If a slight amount of oil oozes from the hole, the level will be correct. If, on the contrary, no liquid oozes from the hole, you should continue to add more oil.
5. If you need to add more oil, you must do so through the filler cap (3).
6. Check for leaks and properly dispose of the used fluid.

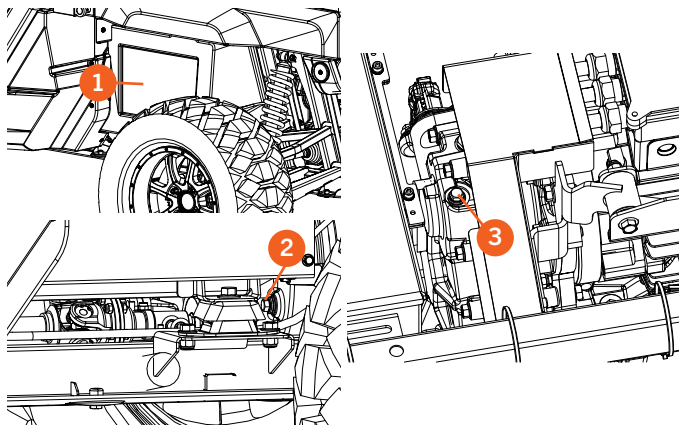

TRANSMISSION OIL (OIL CHANGE)

CHANGE PROCEDURE:

1. Put the vehicle in horizontal position and lift the load box.
2. Remove the rear protector (see page 49).
3. Place a container under the transmission to collect the used oil and avoid any spillage.
4. Remove the filler plug (1), to facilitate a better drainage of the transmission oil.
5. Remove the transmission oil drain screw (2).
6. Once all the oil has drained from the transmission, replace the washer and make sure the drain screw is tightened to 24 Nm.
7. Fill the transmission with new oil.
8. Replace the O-ring and fit the filler plug (1).
9. Check for leaks and properly dispose of the used fluid.

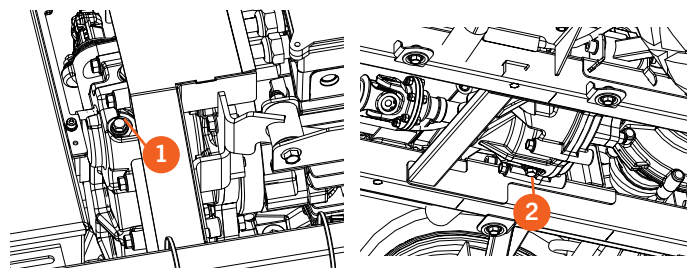

TECHNICAL INFORMATION:

Recommended oil: SAE 80W-90, API GL5.

Capacity: 1.2L.



NEVER drive the vehicle with no or low oil in the gearbox. It is important that you are familiar with the maintenance intervals for the components shown in the service chart.

24. REAR DIFFERENTIAL OIL (CHECK AND CHANGE)

CHECK:

To check the rear differential oil level, you have to drain the oil into a calibrated container and measure the amount that has been extracted. The correct volume is 0.5 L.

CHANGE:

The oil must be changed periodically, to ensure the life of the differential, as indicated in the Service Chart (page 49).

1. Park the vehicle in a totally horizontal position.
2. Before starting the operation, remove the rear underbody protector (p. 51) and lift up the cargo box.
3. Place a container under the differential to collect the used oil and avoid any spillage.
5. Remove the filler plug/screw (1), to facilitate better oil drainage.
6. If it is not possible to access the filler cap from the rear, you will have to remove the side protector (2).
7. Remove the drain cap/screw (3) and wait until all the content has emptied out.
8. Screw on the drain plug/screw (3) and tighten the drain plug, replacing the washer, securing it at 24 Nm.
9. Fill the rear differential with the new oil.
10. Screw on and make sure the corresponding filler plug/screw (1) is tight, replacing its washer, securing it at 24 Nm.
11. Check for leaks and properly dispose of the used fluid.



NEVER drive the vehicle if there is no oil in the rear differential or if the oil level is low.



It is important that you are familiar with the maintenance intervals for the components shown in the service chart. If you notice any leakage from the differential, make sure that



you have enough oil to run the vehicle and contact your nearest Corvus Service Centre.

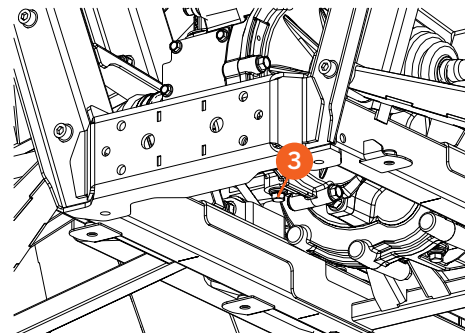
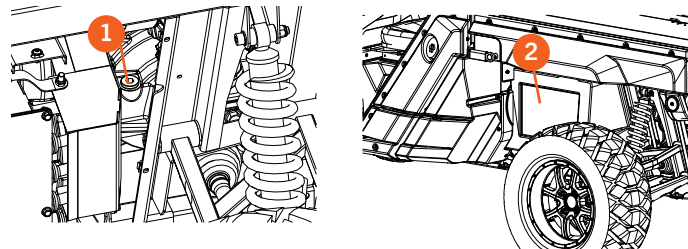

25. FRONT DIFFERENTIAL OIL (CHECK AND CHANGE)

CHECK:

To check the front differential oil level, you have to drain the oil into a calibrated container and measure the amount that has been extracted. The correct volume is 0.5 L.

CHANGE:

The oil must be changed periodically, to ensure the life of the differential, as indicated in the Service Chart (page 49).

1. Park the vehicle in a totally horizontal position.
2. Before starting the operation, remove the front underbody protector (p. 51) and lift up the hood.
3. If necessary, remove the front luggage compartment.
4. Place a container under the differential to collect the used oil and avoid any spillage.
5. Remove the filler plug/screw (1), to facilitate better oil drainage.
6. Remove the drain cap/screw (2) and wait until all the content has emptied out.
7. Screw on the drain plug/screw (2) and tighten the drain plug, replacing the washer, securing it at 24 Nm.
8. Fill the front differential with the new oil.
9. Screw on and make sure the corresponding filler plug/screw (1) is tight, replacing its washer, securing it at 24 Nm.

 **NEVER** drive the vehicle if there is no oil in the front differential or if the oil level is low

 It is important that you are familiar with the maintenance intervals for the components shown in the service chart.

 If you notice any leakage from the differential, make sure that you have enough oil to run the vehicle and contact your nearest Corvus Service Centre.

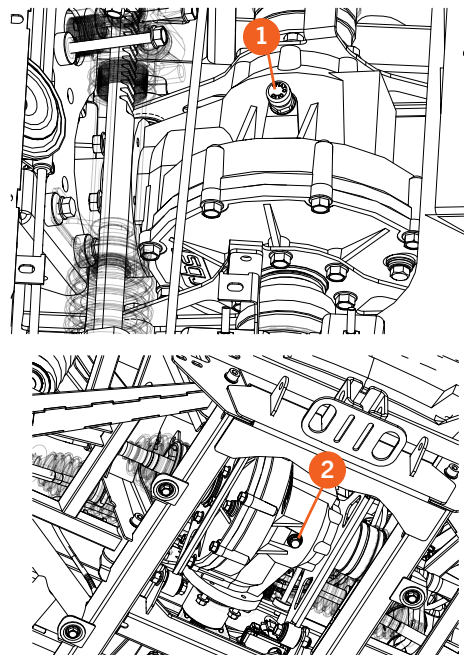

26. 4WD LOCKING SYSTEM OIL (CHECK AND CHANGE)

CHECK:

To check the 4WD lock system oil level, you have to drain the oil into a calibrated container and measure the amount that has been extracted. The correct volume is 0.05 L.

CHANGE:

It is convenient to frequently check that there are no leaks and the maintenance of the oil level, for correct operation.

Changing the locking system oil.

1. Put the vehicle in the horizontal position and remove the front underbody protector (see page 51).
2. Place a container under the 4WD locking system to collect the used oil and avoid any spillage.
3. Remove the filler plug (1), to facilitate a better drainage of the 4WD locking system oil.
4. Remove the drain screw (2) the 4WD locking system oil.
5. Once all the oil has drained out of the system, replace the washer and make sure the drain screw is tightened at 24 Nm.
6. Fill with 0.05 L of new oil.
7. Replace the plug washer and tighten the oil filler plug (1) to 24 Nm.



TECHNICAL INFORMATION:

Recommended oil: SAE 80W-90, API GL5. Capacity: 0.05 L.
Tighten the filler plug/screw to 24 Nm.
Tighten the drain plug/screw to 24 Nm.



NEVER drive the vehicle with no or low oil in the 4WD actuator.

It is important that you are familiar with the maintenance intervals for the components shown in the service chart.

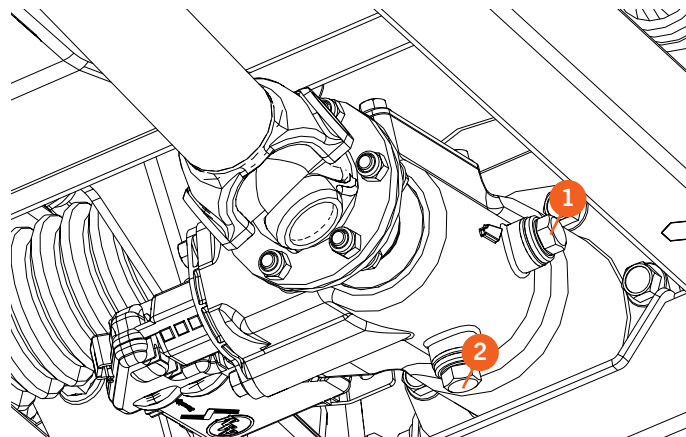

27. GREASE NIPPLES

Your vehicle is equipped with grease nipples to facilitate the lubrication of certain parts (2 in each rear wheel spindle, 2 in each cardan joint and 1 in the transmission cardan/output coupling joint).

- 1- Cardan-driveline hub grease nipple.
- 2- Cardan-driveline hub grease nipple.
- 3- Driveline coupling grease nipple.
- 4- Lower rear wheel spindle grease nipple.
- 5- Upper rear wheel spindle grease nipple.

 The indicated points should be lubricated according to the service chart to prevent rapid wear of the components.

Check regularly to make sure that the grease nipple is still in position. If it falls out, lubrication may be lost and dust or foreign matter can get in, which will accelerate the wear of the components.

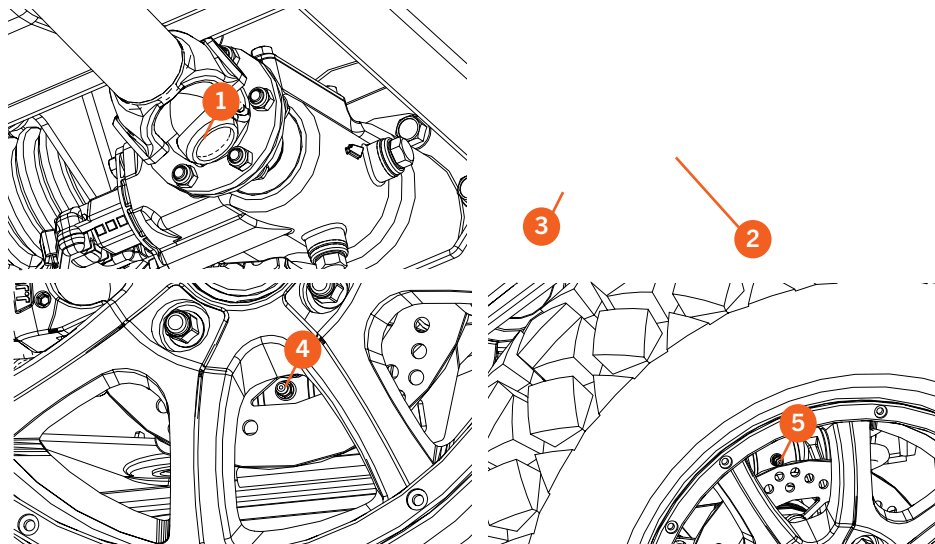

28. LUGGAGE COMPARTMENT HOOD

DISASSEMBLY:

To gain access to the differential and the components located under the hood, it will be necessary to remove the luggage compartment if there is one.

Previously, you need to remove the front hood.

1. Loosen the 5 screws (1) that hold the luggage compartment hood in place.
2. Remove the luggage compartment hood.



TECHNICAL INFORMATION

Fastening torque for lock bolts: 12 Nm.



NEVER drive the vehicle with the luggage compartment hood removed.

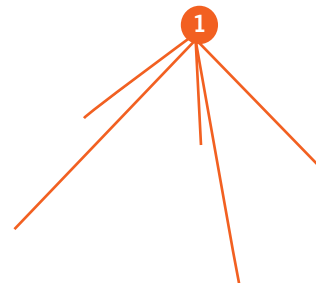

29. LIGHTING

PILOT LIGHTS

The headlamps and the turn signal lamps are located on the **front** of the vehicle:

1. The front low beam headlamps (short) have a screw so you can adjust their height.
2. The front long beam headlamps have screws so you can adjust their height.
3. Front turn signal lamps.

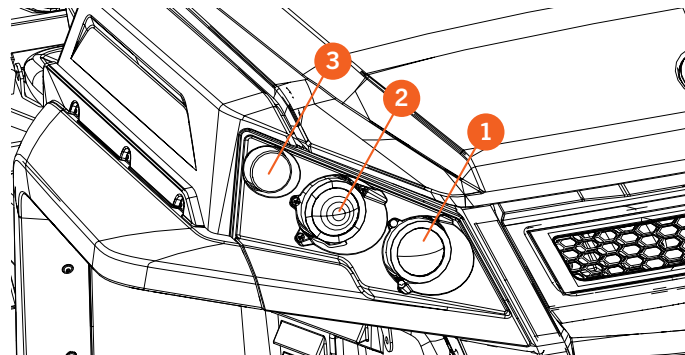

The brake lights/sidelights, the turn signal lamps and the reflectors are located on the **rear** of the vehicle:

4. Reflectors
5. Rear brake and sidelights.
6. Your vehicle also has a number plate light.

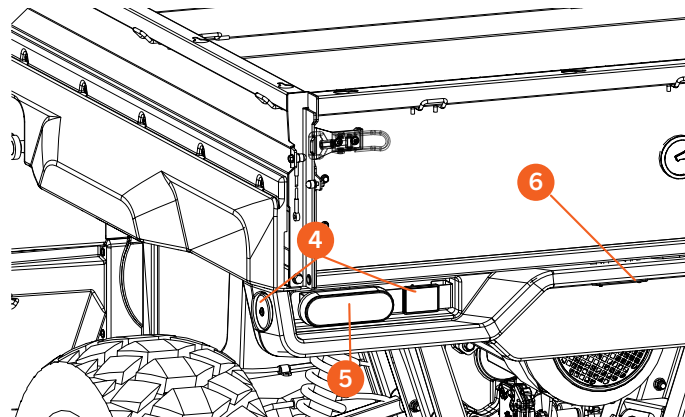

The surface of the lamps may be very hot.

NEVER drive the vehicle without lights or turn signal lamps.

They are an important safety feature.

29. LIGHTING

ADJUSTING THE HEIGHT

1. Position the vehicle 10 meters from a wall and use the parking brake to immobilize it.
2. Use the screws to adjust the headlamps (1).
3. The light beam must be 30 cm below the horizontal line projected onto the wall from the centre of the headlamp.



The bulbs and headlamps may be very hot.

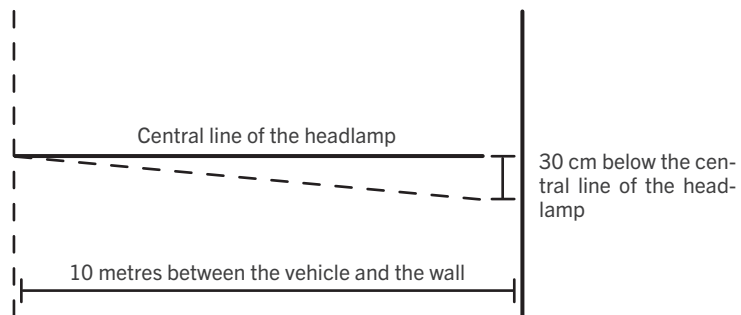
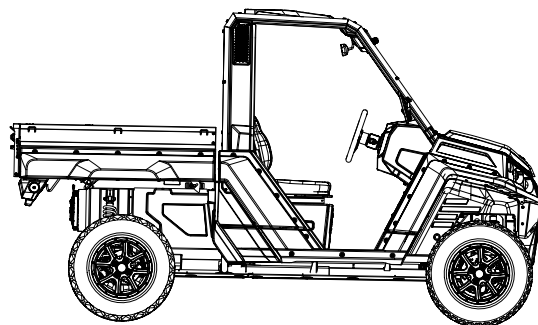

30. FRONT LAMPS (LOW AND HIGH BEAM AND TURN SIGNAL LAMPS)



The bulbs and headlamps may be very hot.

Procedure:

1. Switch the vehicle off.
2. Open the front hood.

Replacing the turn signal lamps:

1. Unplug the electrical connector (1) of the lamp you are replacing.
2. Turn the bulb counterclockwise to remove it from its housing.

Replacing the long-range lights:

1. Unplug the electrical connector (2) of the lamp you are replacing.
2. Turn the bulb counterclockwise to remove it from its housing.

Replacing the sidelights:

1. Unplug the electrical connector (3) of the lamp you are replacing.
2. Insert your hand beneath the lamp until you touch the light.
3. Turn the bulb counterclockwise to remove it from its housing.

Replacing the indicator lamps:

1. To replace the indicator lamps, turn the bulb holder bushing (4) counterclockwise to disconnect it from its housing.
2. Turn the lamp and separate it from the bushing.

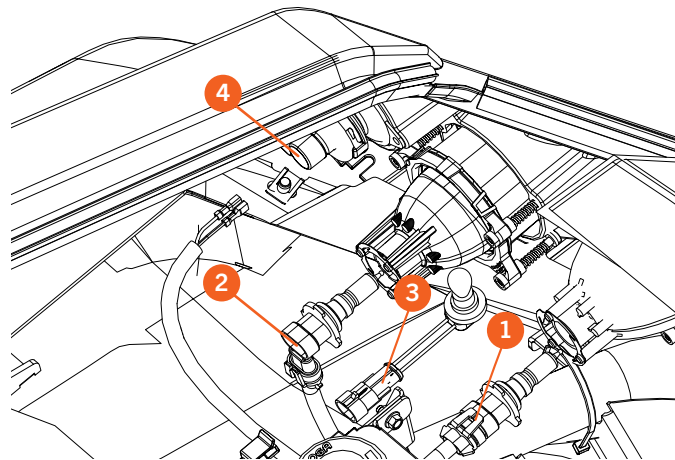

TECHNICAL INFORMATION

Dipped beam lamp: HB3A 12V 60W // Ref. 09180040003

Long-range lamp: HB3 12V 60W // Ref. 08011460000

Sidelights: W5W 12V 5W // Ref: 08011360000

Turn signal lamp 12V 21W //Ref. 08000960000



Do not drive the vehicle without brake, turn signal or sidelights as these are important safety features.

3. LAMPS

NUMBER PLATE HOLDER BULB

To access the number plate holder bulbs, it is necessary to follow these steps:

1. Remove the screws shown (1).
2. Then remove the outer plastic of the lamp (2).
3. Carefully remove the bulb (3).



TECHNICAL INFORMATION

Indicator lamp: 12V 21W // Ref. 09180040001

Brake and sidelight lamp: 12V 21W/5W // Ref. 09180040002

Number plate light bulb: Ref. 08001660000

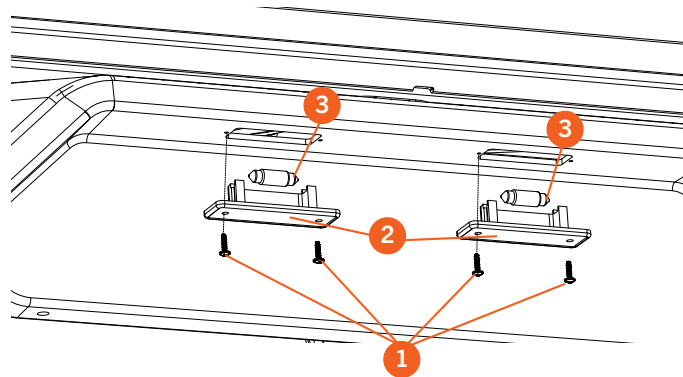

32. TIRES

Check that the tires are not worn, cracked or damaged.
Also check that they are at the correct pressure.

Recommended front/rear pressure:

- 1.0 bar (empty vehicle)
- 1.5 bar (vehicle at full load)

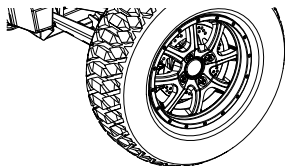

Improper tire maintenance could cause loss of vehicle control and an accident, which can lead to serious injury or even death. To reduce the risk of injury:

- Maintain the recommended tire pressure. Check the pressure before driving. Keep in mind that even driving a short distance can raise the tire pressure reading.
- Use only the specified size and type of tires for this vehicle.
- Do not use your vehicle with worn or damaged tires. Replace them.
- Always follow the tire manufacturer's maintenance instructions.

33. BOLTS, NUTS AND FASTENINGS

Every day before you drive your vehicle you should check that all the nuts and bolts are tight.

You should also check that the other fastenings are in place and in good condition.



NEVER drive with nuts or bolts removed, this could cause an accident or serious damage.

34. ADJUST HANDBRAKE

To adjust the parking brake, follow the procedure below:
Loosen the nut (1) and separate the pads by loosening the axle (2).
Adjust the cable stud so that the distance between the nut and the end of the stud is 10 mm.
Adjust the cam until the indicated dimension (60-61 mm) is reached when the hand brake is off.
Slowly move the pads towards the disc, tightening the axle (2), until they touch.
Loosen the axle by 90°, moving the pads away from the disc.
Tighten the nut (1) by holding the axle (2) with a flat screwdriver.



TECHNICAL INFORMATION

The cam must be adjusted in such a way that when the parking brake is applied to its maximum extent, the angle of the cam with reference to the cable has to be 85° at the most.



Do not carry out this operation when the handbrake is on. Only activate it when the nut (1) is tightened.

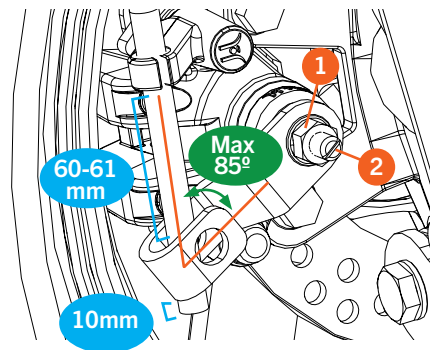

35. BRAKE WEAR

If the thickness of any of the front or rear disc brake pads is less than 1.5 mm, completely change the set of affected pads.

 Check that the front and rear axle discs are at least 3.5 mm thick.

It is important to keep the area around the discs, pads and wheel spindles clean. Do not allow mud or external elements to accumulate over long periods of time. These elements can affect the performance, effectiveness and life of the materials.

 We recommend that you go to your CORVUS dealer to change the brake pads. They will also check for any possible wear of the brake discs.

36. BRAKE FLUID

Inspect the brake fluid and change it regularly. You must also change it if is contaminated by water or dirt.
Recommended fluid: DOT-4 brake fluid.

 Do not mix different types of brake fluid. The fluid used to fill or renew your circuit must respond to the specified standard in the fluid reservoir of each circuit. You should NEVER change the specification, always respect the dot-4 specification. What is important is not that the brake fluid should be the same brand, rather that it MUST HAVE the same specification. NEVER use fluid from a container that is not sealed (unopened) at source. NEVER use brake fluid that has already been used.

The brake fluid level must be within the MIN/MAX range. If there is not enough liquid, it should be added.

 Do not spill brake fluid on paintwork.

 Check that there is no loss of liquid through the gaskets. Check for possible damage to the brake sleeves.

It is recommended that you replace the brake fluid every 2 years.

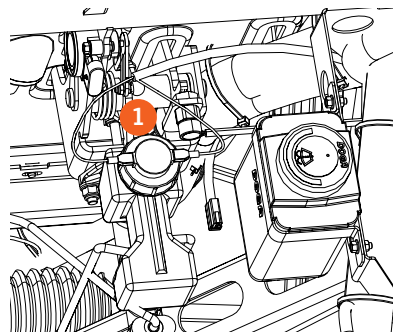

37. AUXILIARY BATTERY

The battery (12 V and 55 Ah) does not need maintenance.

CHANGING THE BATTERY

The battery is located at the right rear of the vehicle, under the right-hand spray shield or right-hand side box.

To change it, perform the following steps:

1. Loosen the 5 screws (1) securing the spray shield and remove it.
2. Remove the screw (2) securing the battery nail.
3. Loosen the battery terminals and remove the battery, first the negative terminal (A) and then the positive terminal (B).

Replace the battery with a new one and follow the steps in reverse order to reassemble it.



Do not handle or attempt to open the battery, the electrolyte and gases are toxic and can cause serious injuries. Keep the battery away from heat sources, open flames, and sparks. Always store and charge the battery in well-ventilated areas. Always disconnect the negative terminal first and connect it last. Use protective clothing and goggles. Contact with skin, eyes, or clothing can cause severe burns. Antidotes:

External: Rinse with water.

Internal: Drink plenty of water or milk. Follow with milk of magnesia, beaten egg, or vegetable oil. Contact a doctor immediately.

Eyes: Rinse with water for 15 minutes and seek medical attention promptly.

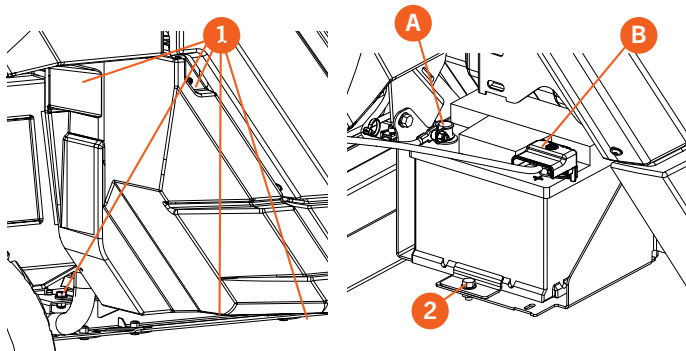

38. BATTERY

The batteries are housed at the rear in a protective box: it is necessary to know their limitations in order to avoid failures or dangerous situations:

- Do not charge the batteries by any method other than the Corvus charging point.
- Handling batteries can result in electrical failure, component rupture or fire.
- Handling battery management systems may result in electrical failure, component breakage or fire.
- Do not wash the battery components with high-pressure water.
- To avoid poor contacts or electrical problems, keep terminals and connections clean from foreign matter and rust.
- Do not operate or charge the vehicle at temperatures above 40°C.
- The vehicle should not be used below -14 °C. If the battery temperature falls below 0 °C and you do not have thermal blankets, you will not be able to charge the battery.
- Avoid allowing the charge to fall below 20%, as the battery may go into deep discharge.
- Failure to comply with any of these instructions may result in electrical failure and/or loss of warranty.

FACTORS AFFECTING VEHICLE RANGE

When calculating the distance your vehicle can travel on a single battery charge, consider the following factors:

Type of terrain:

Sloping or unstable terrains require more energy consumption..

Weather conditions:

Strong headwinds, slippery terrain, or extreme ambient temperatures can reduce the vehicle's range.

Driving mode:

Driving modes such as 4x2 or 4x4 traction and low or high gear require different levels of power to the motor and different energy consumption.

Driving style:

Aggressive driving requires more power than cautious driving.

Frequency of starts and stops:

More battery energy is consumed when accelerating to cruising speed than when maintaining it.

Number, condition, and size of the tires:

The vehicle requires more power when carrying passenger, cargo or a trailer.

38. BATTERY

 It is necessary to charge the vehicle periodically, at least once a month, especially if the vehicle is new.

Always charge cycles up to 100% and let the charger stop.

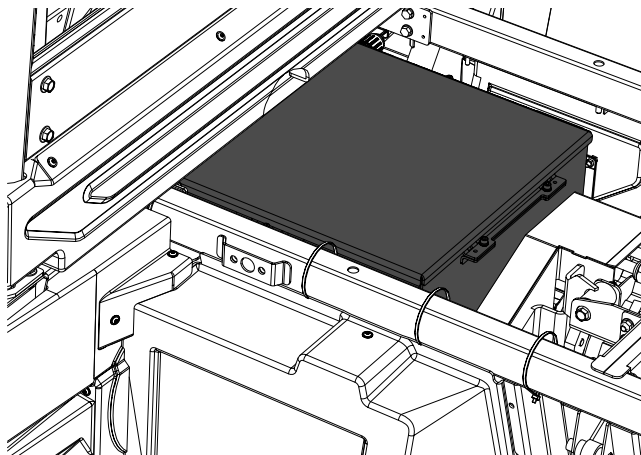

 As the battery capacity may be affected by external temperature, it may not work under extreme conditions. The optimum operating temperature is 25°C.

Battery life will depend on both how the vehicle is used and on external conditions. The maximum running time is 100 km under optimum conditions.

Maximum charge capacity will be obtained after several charge cycles. It is advisable to fully charge the battery after each use.

 Failure to charge the vehicle can result in unrecoverable battery failure.

39. ENGINE

The 13KW induction engine is located at the rear, beneath the cargo box. It is connected directly to the transfer case and from there to both differentials.

It is responsible for steering, therefore, when switching to reverse gear there is no actual physical change, only an electrical change in the engine.

The engine is cooled by a fan (1) located at the rear. This area must always be kept in good working order which means that no foreign matter, such as dust or mud, should be allowed to build up on the engine, as the engine's service life will depend on it being kept clean.

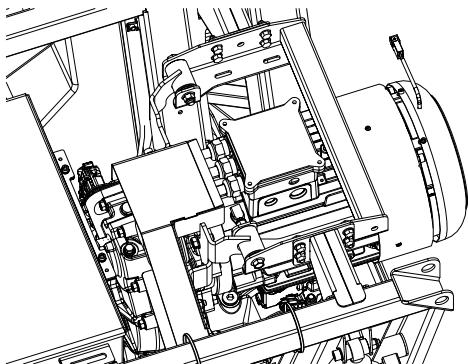

One of the engine's main features is the ability to modify its power range depending on the driving use.

POWER: the vehicle will deliver maximum power, but the battery life will be shortened.

RANGE: is a moderate engine mapping that allows for longer battery life by reducing engine power.

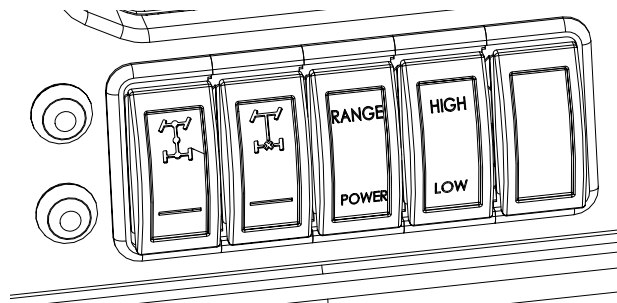

Do not drive the vehicle if the fan is not working. Always keep the engine area clean as this will help the engine to cool down properly.

It is not possible to change gear or direction while the vehicle is in motion; to make any such change, the vehicle must come to a complete stop beforehand.

Continued use of the Power mode will discharge the battery rapidly.

40. FUSES

LOT 1

To access the fuse box, you will need to remove the 2 screws on the cover located to the lower left-hand side of the driver's seat.

Si el tipo de motor se parase inesperadamente y/o no arrancara, o si el vehículo presentara otro tipo de fallo eléctrico, es posible que sea necesario sustituir un fusible. Busque y corrija todo cortocircuito que pueda haber causado que se quemara el fusible y sustitúyalo.

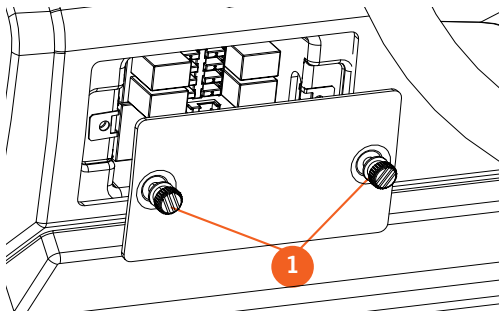

! NEVER use fuses other than those indicated, as this could lead to malfunction or failure of the electrical system.

- F1 - Trailer supply // Alimentación remolque
- F2 - Lighter // Mechero
- F3 - Signal KEY // Señal LLAVE
- F4 - Light // Luces
- F5 - Low and brake light // Cortas y luces de freno
- F6 - Key switch // Interruptor de arranque
- F7 - Dashboard // Tablero multifunción
- F8 - VCU
- F9 - GPS supply // Alimentación GPS
- F10 - Signal // Señal
- F11 - EPS // Dirección asistida
- F12 - Not used // Sin utilizar
- F13 - 48V signal // Señal 48V
- F14 - Converter DCDC // Conversor DCDC
- F15 - Motor fan // Ventilador de motor
- F16 - Not used // Sin utilizar
- R1 - Auxiliar supply // Alimentación auxiliar
- R2 - Lighter and signal // Señal y mechero
- R3 - Lights // Luces
- R4 - Motor fan // Ventilador de motor
- R5 - Battery switch // Interruptor de batería
- R6 - Not used // Sin utilizar
- R7 - Reverse relay // Relé de marcha atrás
- R8 - Forward relay // Relé de marcha adelante

TOP//SUPERIOR

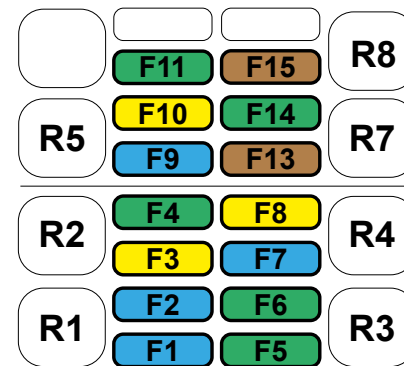

30A 20A 15A 10A

*: Optional // Opcional

4. WINDSHIELD WIPER

WINDSHIELD WIPER BLADE *

To remove the windshield wiper blade:

- 1 - Separate the windshield wiper arm.
The arm and the blade must form an angle of 90°.
- 2 - Press the central clip.
- 3 - Remove the blade downwards.

To assemble the blade:

- 1 - Place the windshield wiper arm between the blade.
- 2 - Place the tip of the arm onto the central clip.
- 3 - Twist the blade and return the arm to its initial position.

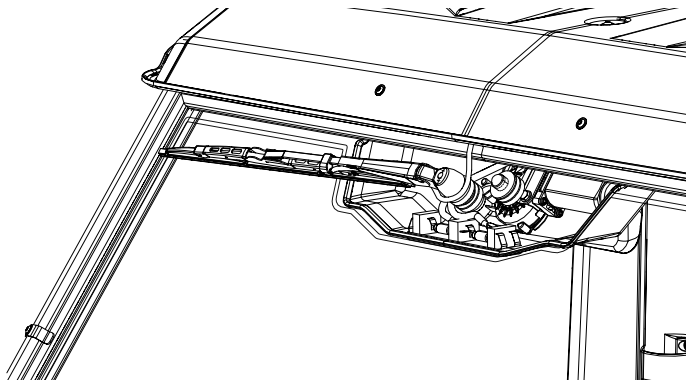

WINDSHIELD CLEANER FLUID *

The windscreen wiper fluid reservoir is located under the front hood.

- 1 - Put the vehicle in a horizontal position.
- 2 - Remove the cap.
- 3 - Fill the tank with fluid up to the top.
- 4 - Screw the cap back on.
- 5 - Check it works properly.

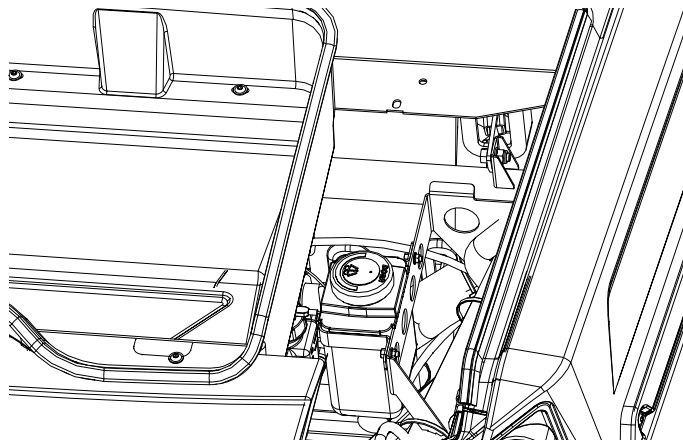

NOTES



WWW.CORVUS-UTV.COM